

Power Management of Hybrid Renewable Energy System by Frequency Deviation Control

M.Sivaram Krishnan^{#1}, M.Siva RamKumar^{*2}, M.Sownthara^{#3}

^{#1}PG Scholar, Department of EEE, Sri Krishna College of Technology, Coimbatore, Tamil Nadu, India.

^{*2}Assistant Professor, Department of EEE, karpagam university, Coimbatore, Tamil Nadu, India.

^{#3}PG Scholar, Department of ECE, karpagam university, Coimbatore, Tamil Nadu, India.

ABSTRACT— In this paper, a novel control strategy for frequency control in stand-alone application based on coordination control of fuel cells (FCs) and ultra capacitor (UC) bank in an autonomous hybrid renewable energy power generation system is implemented. The proposed renewable energy power generation subsystems include wind turbine generator (WTG), photovoltaic system (PV), FC system and the UC bank as energy storage system. The system performance under different condition has been verified by using real weather data. Simulation results demonstrate the validity of proposed studied hybrid power generation system feeding isolated loads in power frequency balance condition.

KEYWORDS— Wind turbine generator (WTG), ultra capacitor (UC), fuel cell (FC), photovoltaic (PV), frequency control.

I. INTRODUCTION

Stand-alone power generation systems are utilized by many communities and remote area around the world that have no access to grid electricity. The renewable energy in grid independent system is growing due to rising fuel prices and environmental warming and pollution [1, 2].

Wind and solar power generation are two of the most attractive renewable power generation technologies. In order to integrate renewable energy into such systems and to prevent power fluctuation of wind and solar resources due to weather condition variation, some form of energy storage or additional generation such as FC and battery bank is generally needed. [3, 5].

FCs systems are one of the promising energy technologies for sustainable future due to their high energy efficiency, environment friendliness and modularity. The main drawback of FCs power generation system is slow dynamics because the FC current slope must be limited in order to prevent fuel starvation problems and to improve its performance and lifetime. The very fast power response, flexible and modular structure of an ultra capacitor can complement the slower power output of the main source to satisfy load demand completely [6].

A hybrid power system consists of a combination of two or more power generation technologies to enhance their operating characteristics and efficiencies than that can be obtained from a single power source [7].

The power for the load demand can be effectively delivered and supplied by the proposed hybrid power generation system with proper control and effective coordination among various subsystems. A number of literatures have been reported to investigate frequency deviation control and modeling of hybrid renewable energy systems. Among them, Dong Jing and Lee Wang reported the small signal stability analyzes of a hybrid power generation/storage system connected to isolated load [8], [9]. In [10], S. Doolla and T.S. Bhatti investigated the load frequency control of an isolated small-hydro power plant with reduced dump load technique. In [11], dynamic model of FC are simulated as first order lead-lag to indicate the exact behavior of FC system in transient event based on experimental data. Output Power Control of Wind Turbine Generator by Pitch angle control is presented in [12] and [13].

In the previous works, the authors used the diesel generators and battery bank to control frequency deviation

control with different control strategy. The main contribution of this research is that a novel control strategy for frequency deviation control of stand-alone autonomous hybrid power generation based on coordination of FC and UC is proposed to enhance power quality. Also, the studied hybrid power generation is investigated under real weather data and the simulation result is used to validate the effectiveness of the proposed control strategy.

This paper is organized as follows: in Section 2, system descriptions and methodology are explained, power management and proposed control strategy is described in section 3. Simulation and results discussion are presented in section 4 and the research will be concluded in Section5.

II. SYSTEM CONFIGURATION AND DESCRIPTION

The generalized block diagram of the proposed hybrid power generation/energy storage system is shown in Fig. 1. In a power generation subsystem which includes a WTG, a PV and a FC system, a UC bank is employed as energy storage system. UC is assumed to have enough capacity to store surplus energy generated subsystem. In the proposed system a PV and a WTG system are used as primary energy power generation and have priority to produce the power to satisfy load demand.

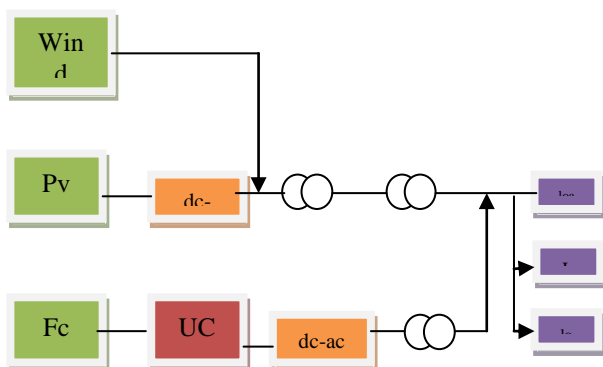

Fig. 1. Overall system configuration of the hybrid power generation and energy storage system

In the proposed system to simulate and investigate all part of system the simplified model as linear first order transfer function are generally employed. Therefore, the system nonlinearities have not been taken into account and the system simulated in simplified model this linearized model has good precession for frequency deviation in small signal study. The mathematical models of the different components are presented in sub-section.

A. Wind Power Generation Model

The output power of wind turbine generators depends upon the wind speed. The mechanical power of the wind turbine is given in [12] as:

$$P = \frac{E}{t} = \frac{1}{2} A \rho v^3 \tag{1}$$

where ρ , A , C_p are the air density, swept area of blades, and power coefficient which is a function of tip speed ratio.

The maximum rotor efficiency C_p is obtained at a special λ , which depend on the aerodynamic design of a given turbine. To keep λ constant at the optimum level at all times, the rotor must turn at high speed at high wind, and at low speed at low wind. Fig.2. indicates $C_p - \lambda$ characteristics of the Wind turbine generator at different pitch angles (θ).

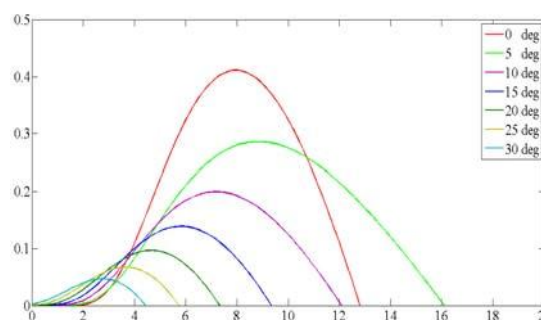

Fig. 2. $C_p - \lambda$ characteristics of the wind turbine generator at different pitch angles (θ).

Fig. 3 expresses the output power of the wind turbine generators in comparison with wind speed. This figure indicates that the output power is maintained constant when wind speed is higher than the rated wind velocity. This is done with the aim of the pitch angle control to protect the electrical system and to prevent the rotor from over speeding.

In this study, when wind speed is greater than the cutout speed (25 m/s), the system is taken out of operation for safety of its components and when wind speed is greater than cut-on wind speed, the output power of WTG is constant at its maximum value by the pitch angle control. However, when wind speed is smaller than cut in speed 4 m/s, the output power of the WTG is zero.

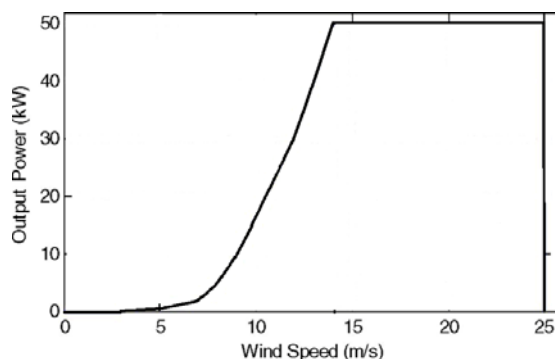

Fig. 3. Wind turbine output power characteristic curve

B. Photovoltaic Power Generation Model

A photovoltaic system consists of one or several photovoltaic generators connected in series and parallel to provide the desired voltage and current. Photovoltaic generation systems are currently considered to be one of the most promising energy sources. PV generation is a flexible and environmental friendly power generation method. The electrical data of photovoltaic (PV) modules are influenced by solar radiation, solar cell temperature and area of PV array. The output power of the PV system can be express as follow.[9].

$$P_{PV} = \eta S \gamma (1 - 0.005(T_a + 25)) \quad (2)$$

The PV power extracted from the solar irradiation mainly depend upon four quantities namely, conversion efficiency of PV array (η), measured area of PV array(S), solar irradiation (γ), ambient temperature (T_a).

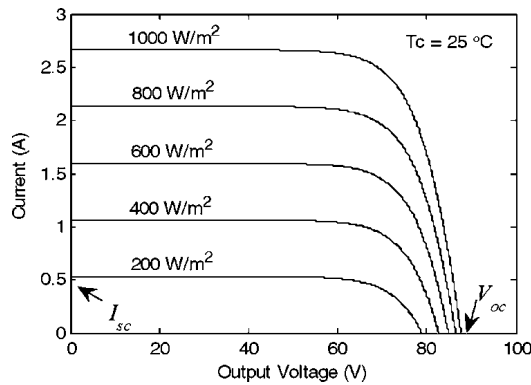

Fig. 4. I-V characteristic curves of the PV model at different irradiances.

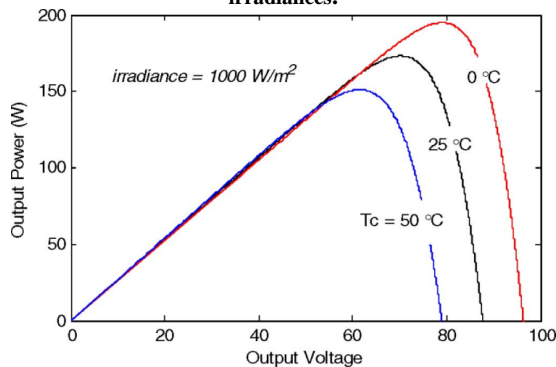

Fig. 5. P-V characteristic curves of the PV model at different operating temperatures

C. Fuel Cell Power Generation System

Fuel cells are static energy conversion devices that use hydrogen and oxygen to convert chemical energy into electrical energy. However, the main drawback of fuel cell is slow dynamic due to their slow dynamic in the fuel supply system, which contains pumps and valves [1,2,4].

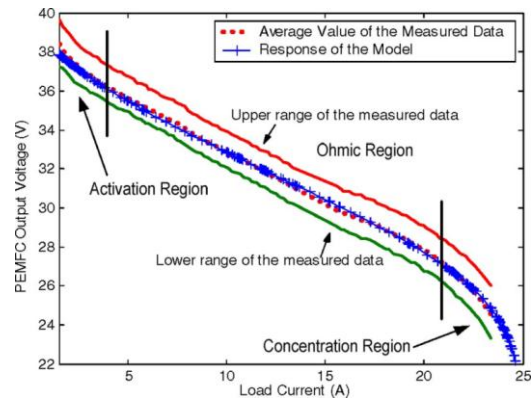

Fig. 6. PEMFC V-I characteristic: comparison of model response with experimental data

D. UC Bank Storage Subsystem

Recently, ultra-capacitors (UCs) are being attracted as future replacements for the batteries in different applications due to high efficiency, fast load response, modularity, long life, maintenance and environmental friendly.

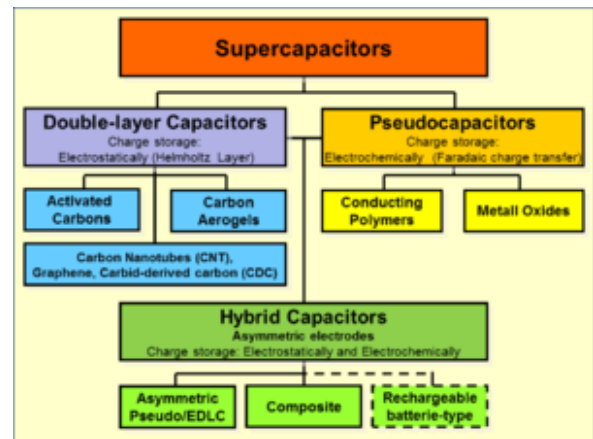

Fig 7 : Hierarchical classification of supercapacitors and related types

E. Power Deviation And System Frequency Variation

The total power generation must be effectively controlled and properly dispatched to maintain a stable operation of an autonomous system to satisfy power demand of isolated load by proper control of different power generation and components. The power balance is expressed as follow:

$$\Delta P = P_{Net} - P_{load}$$

III. MODELING AND PROPOSED CONTROL STRATEGY

Modeling and control strategy of proposed system are explained in this section. In the proposed system PV and WTG systems are used as main and primary power sources to produce power. But the power generated by integration of them highly depends on whether condition. The power generated by WTG and PV are combined

with FC to supply required power demand of connected load. The residual power of the studied hybrid system due to slow dynamic of systems is properly satisfied by UC system. The net power generation is comprised by the power WTG, PV, FC and UC system.

The expression for P_{Net} is given by

$$\rightarrow P_{Net} = P_{WTG} + P_{PV} + P_{FC} \pm P_{UC}$$

To solve this problem, the integration of UC and FC system is used as back-up system. In the proposed control system, a high-pass filter (HPF) is used to reduce charging and discharging of UC bank in long-term. The frequency deviation of overall system divided in two parts with the aim of HPF. UC bank compensates high frequency deviation due to its fast response and FC system compensates low frequency deviation [1, 10].

IV. SIMULATION RESULTS

The real wind speed and solar irradiation for the proposed method is shown in Fig. 5 and Fig. 6. respectively.[8] Simulation results are shown in Fig.7 to Fig 12. Fig. 7 and Fig.8 are the output power of WTG and PV systems. Steps load demands are applied to this system to show the effectiveness of proposed control strategy as shown in Fig.9. Fig. 8 and Fig. 9 are the output power of FC and UC systems.

The Fig.12 shows that the frequency deviation can be control appropriately by coordination between FC and UC to compensate the shortage and to complement whole hybrid power generation with considering the effects of system frequency variation.

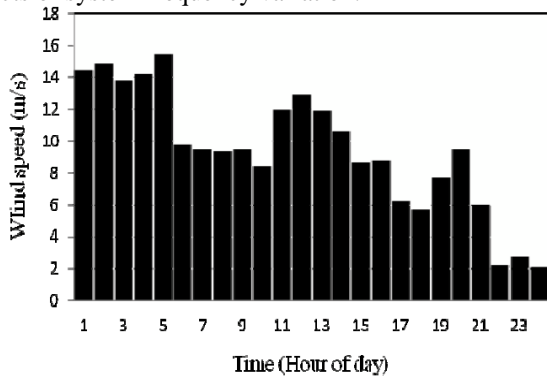

Fig. 5. Real wind speed data used for proposed system simulation

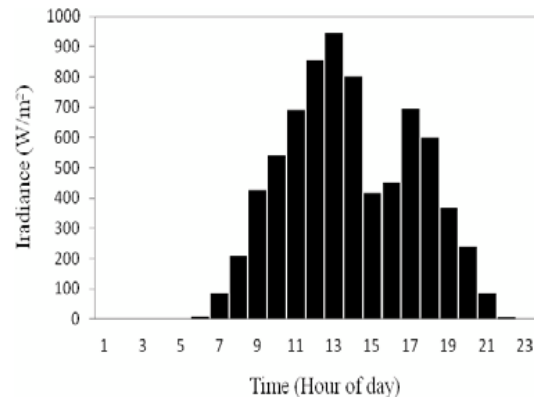

Fig. 6. Real irradiance data used for proposed system simulation

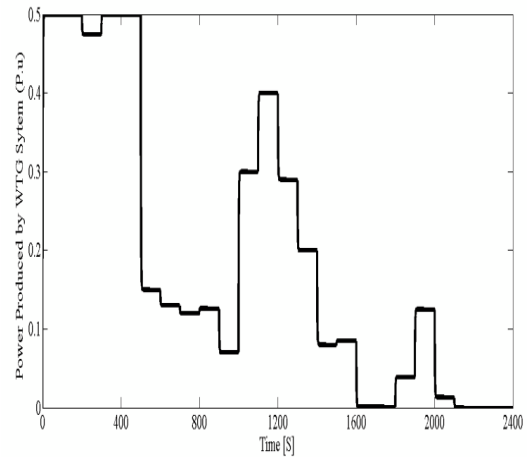

Fig. 7. Power produced by wind turbine generator

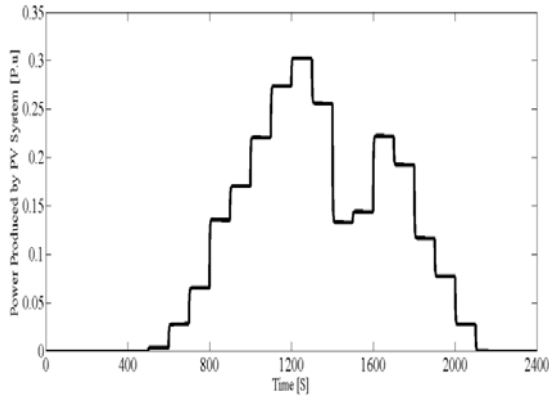

Fig. 8. PV power generated for whole day

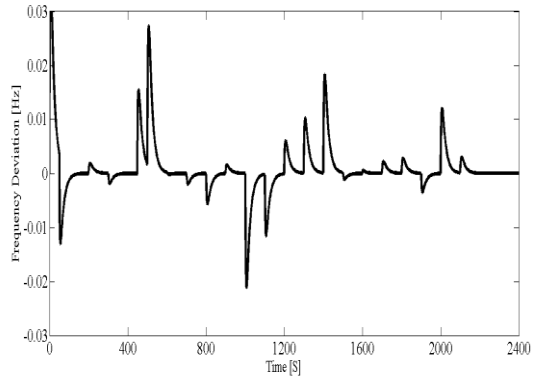

Fig. 12. Frequency deviation

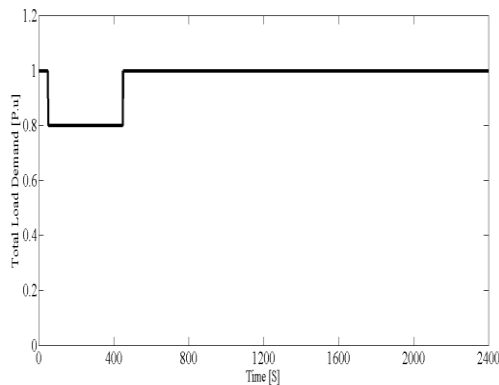

Fig. 9. Variation of load demand

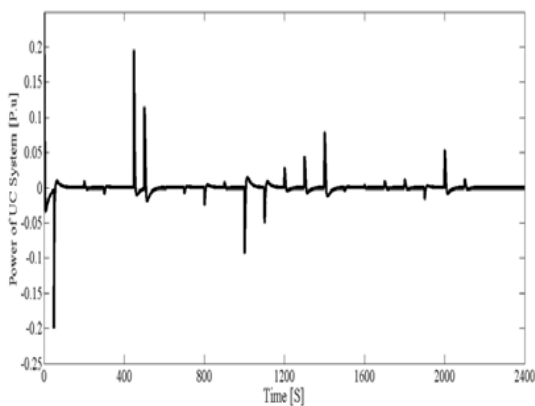

Fig. 10. Battery output power

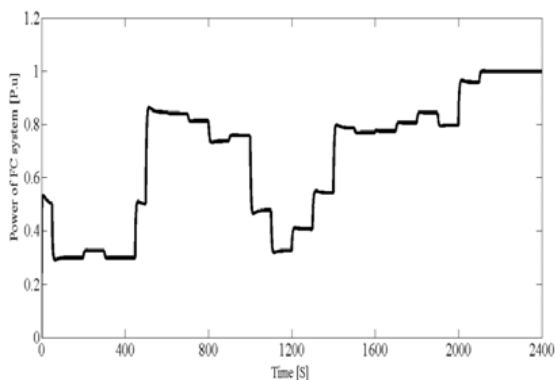

Fig. 11. Power supplied by the FC stack for whole day

V. CONCLUSION

In this paper, an ac-linked stand-alone wind/PV/FC alternative energy system is proposed. The system configuration and unit-sizing are discussed; the characteristics of the main components in the system namely the WECS, PV, FC, and UC are given; and the overall control and power management strategy for the proposed hybrid energy system is presented. The wind and PV generation systems are the main power generation devices, and the FC and UC system is the backup generation and supplies power to the system when there is power deficit. The simulation model of the hybrid system has been developed using MATLAB/Simulink. Wind and solar power are safe, and do not send emissions or residues to the environment. The production of clean energy, which is harmless and does not aggravate the greenhouse effect, must be promoted. The use of electricity generated from renewable non-pollutant energy sources (green electricity), and all technologies involved must increase. The scientific community is also contributing with technological innovations. Nowadays, the development of Power Electronics enables economical solutions for the production of renewable energy based on small power plants. Portugal presents good conditions for the implementation of a large number of these systems, based on wind power and photovoltaic energy. This paper proposes the development of a low-cost high efficiency hybrid system (wind and solar) with an interface to the electrical grid that ensures the power quality of the produced energy. The proposed solution may be a contribution to a better, cleaner and safer environment and to a decrease in energy dependence.

REFERENCES

- [1] Intelligent Model-based Control Of A Standalone Pv/Fc Power Plant With Sc Energy Storage”, IEEE Transactions On Sustainable Energy, Vol. 4, No. 1, January 2013.
- [2] Amine Lahyani, Pascal Venet, Abdessattar Guermazi, and Alaeddine Troudi “Battery/Supercapacitors Combination in

- Uninterruptible Power Supply (UPS)” IEEE Transactions On Power Electronics, Vol. 28, No. 4, April 2013.
- [3] M. Nayeripour and M. Hoseintabar, “control of hybrid renewable energy system by frequency deviation control “ IACSIT International journal of engineering and technology, vol.4, no 3, june 2012
- [4] K. Sedghisigarchi, “Solid oxide fuel cell as a distributed generator: Dynamic modeling, Stability analysis and control, a dissertation submitted in partial fulfillment of the requirement for the degree of doctor of philosophy in kengineering,” West Virginia University 2004.
- [5] N. Kasa, T. Iida, and L. Chen, “Flyback inverter controlled by sensorless current MPPT for photovoltaic power system,” *IEEE Trans. Ind. Electron.*, vol. 52, no. 4, pp. 1145–1152, Aug. 2005.
- [6] S. M. Lukic, J. Cao, R. C. Bansal, F. Rodriguez, and A. Emadi, “Energy storage systems for automotive applications,” *IEEE Trans. Ind. Electron.*, vol. 55, no. 6, pp. 2258–2267, Jun. 2008.
- [7] A. Lahyani, P. Venet, and A. Troudi, “Design of power sharing system between supercapacitors and battery in an uninterruptible power supply (UPS),” presented at the IEEE 33rd Int. Telecommun. Energy Conf., Amsterdam, The Netherlands, Oct. 9–13, 2011.
- [8] Dufo-Lopez R, Bernal-Agustin JL. Multi-objective design of PV–wind–diesel– hydrogen–battery systems. *Renewable Energy* 2008;33:2559–72.
- [9] Dufo-López R, Bernal-Agustín JL, Contreras J. Optimization of control strategies for stand-alone renewable energy systems with hydrogen storage. *Renewable Energy* 2007;32:1102–26. *conference on Power Electronics and Motion Control*, 2006, pp. 1614-1619.
- [10]. M. H. Nehrir, C. Wang, K. Strunz, H. Aki, R. Ramakumar, J. Bing, Z. Miao, and Z. Salameh, “A review of hybrid renewable/alternative energy systems for electric power generation: Configurations, control, and applications,” *IEEE Trans. Sustain. Energy*, vol. 2, no. 4, pp. 392–403, Oct. 2011.

