

Activation of Reparative Osteogenesis by Means of Ultrasonic Action in Treatment of Open Fractures

Leonid Reznik^{1*}, Konstantin Rozhkov¹ and Alexey Novikov²

¹Department of Traumatology and Orthopaedics, Omsk State Medical University, Omsk, Russia

²Department of Mechanical Engineering and Material Science, Omsk State Technical University, Omsk, Russia

Mini Review

Received date: 27/12/2016

Accepted date: 29/03/2017

Published date: 05/04/2017

*For Correspondence

Leonid Reznik, Department of Traumatology and Orthopaedics, Omsk state medical university, Omsk, Russia,
Tel: 79136306653.

E-mail: omsktravma@mail.ru

Keywords: Open fractures, Ultrasonic treatment, Stimulation of bone formation

ABSTRACT

Violation of reparative regeneration of bone tissue in treatment of open fractures is an actual problem. The main method of treatment of open fractures - extra focal osteosynthesis - does not solve all the problems of treatment, as regeneration requires stimulation. One of the stimulating factors is low-frequency ultrasound. The article describes a new method of activating regeneration by sonication and device for its implementation, ensuring the results in the improvement of treatment of open fractures through a combination of extra focal osteosynthesis and low-frequency ultrasonic treatment. It is visible that the contact ultrasonic treatment promotes earlier pain relief, increased density of callus, reduces the effects of unfavourable factors that lead to the formation of sluggish consolidation, pseudoarthrosis. Thus, the contact ultrasonic treatment under extra focal transosseous osteosynthesis improves the results of treatment of open fractures

INTRODUCTION

Violation of reparative regeneration of bone tissue in treatment of open fractures is an urgent problem ^[4,2]. The frequency of unsatisfactory results of the treatment of these fractures remains high (30%) ^[3]. The main factors of bone regeneration disorders in conditions of open fractures are following: damage to soft tissue, soft tissue tropism violation, violation of bone trophic and infectious agents from entering into the injury site. The main method of surgical treatment of open fractures of long bones is transosseous osteosynthesis. However, isolated use of external fixation does not solve all the problems of an open fracture ^[4]. The presence of two or more adverse factors (presence of wounds, crushing of soft tissue, bone defect, infection) is an indication for stimulation of reparative osteogenesis. ^[3] Stimulation may be accomplished by a variety of factors, including methods using physical impact, in particular ultrasound ^[5-10]. Ultrasonic vibrations passing through the soft tissue are damped ^[7]. Therefore, the larger the array of soft tissue to bone is, the lower is the intensity of ultrasonic vibrations reaching the bone and the less the effect of ultrasound. Obviously, the closer is the ultrasonic transducer to the bone; the greater is the effect of ultrasonic treatment.

The aim of the article is to analyze the characteristics and specific hardware of the new method of activation of reparative osteogenesis when combined extrafocal transosseous osteosynthesis and prolonged contact ultrasonic treatment, and evaluation of the dynamics of general clinical and bone-specific indicators characterizing the process for regeneration of bone tissue.

Studies were carried out on adult mongrel dogs, weighing $22.7 \text{ kg} \pm 4,1$ ($M \pm \sigma$), who were divided into 2 groups of 7 animals ($n=7$), a total of 14 animals. The first group was the main, the second one – the controlled. The model was performed on an open fracture of the humerus. Osteosynthesis was performed by model of external fixation device, consisting of 2 standard diaphyseal rods - screws and 2 bars - cannulated screws for external fixation device (patent RU 143 507 U1, 2014109497/14, 12.03.2014) and in trims of external fixation device. Each fragment was recorded at 2 rods - cannulated one more close to the point of fracture, standard one - farther from the fracture site (**Figure 1**).

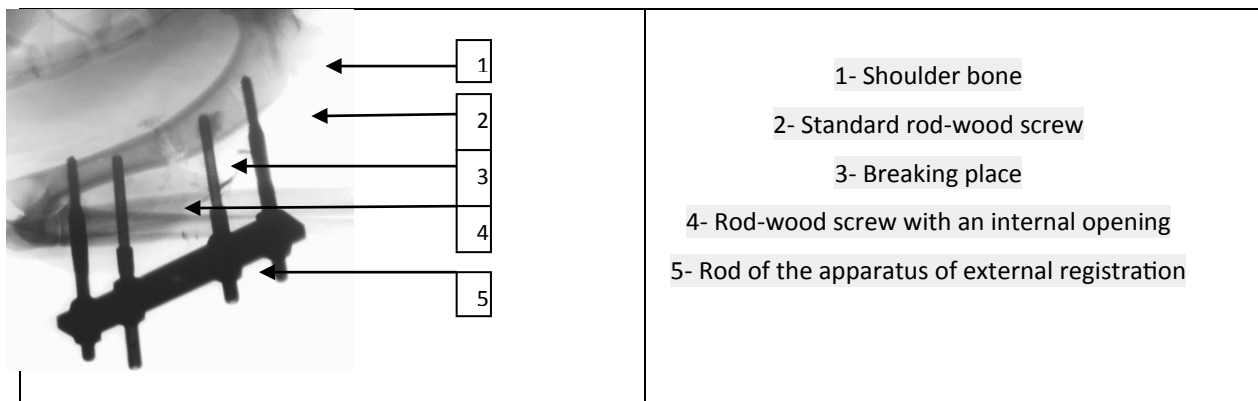

Figure 1. Postoperative roentgenogram.

Animals were divided to 2 groups: controlled one - which did not receive ultrasonic impact during treatment - and the main, animals of which received a daily ultrasonic low-frequency impact during treatment (for 42 days). Applied way of activation of reparative bone formation^[11], in conditions of out-spot osteosynthesis, assumes introduction of through bone low-angle rod to the given depth at a range 20-40 mm from the place of breaking to proximal and distal fragments, and then introduction of ultrasonic waveguide-tool through the cavity of the rod so that it supported an inside edge low-angle of rod on 3-15 mm and subsequent sound of damage area by low-frequency ultrasonic oscillations with parameters 26-42 kHz and amplitude from 15 mkm to 30 mkm with duration of impact from 2 to 15 min with simultaneous submission of medical medicinal solution to the area of impact. This technique was realized with the aid of specially developed device (Figure 2).

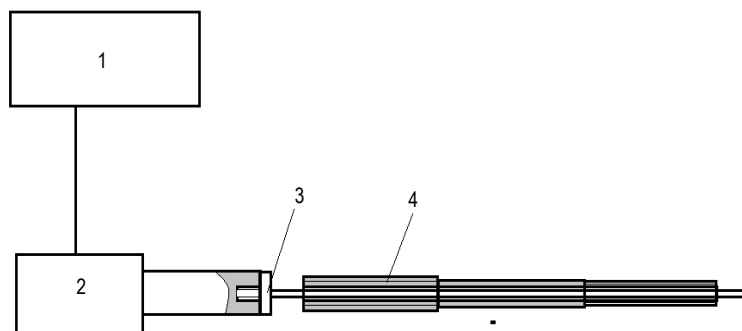

Figure 2. The function chart of the device of activation.

The device of activation of reparative bone formation^[12] contains an ultrasonic generator 1, piezoceramic ultrasonic radiator 2, connected with the exit of ultrasonic generator, waveguide-tool 3, having at the top contact platform, threaded section and working part which is a direct rod with diameter, less through aperture in the hollow rod-screws 4, having in bottom half self-driving and thread-forming part, and on the other hand - the slide section and threaded part, exceeding of its length on 5-15 mm., connected to the butt of piezoceramic ultrasonic radiator by threaded section with contact platform. 3 enter waveguide tool to bone through aperture in hollow rod-screws 4 (Figure 3) depending on required zone sounds that he supports in-bone edge low-angle of rod-wood screw on 3-15 mm.

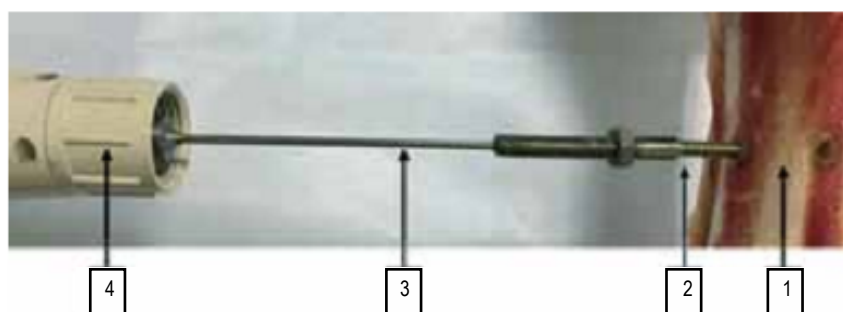

Figure 3. Introduction of ultrasonic tool to hollow rod-screws.

1-Bone, 2-Hollow rod-screws, 3-Waveguide tool, 4-Ultrasonic acoustic knot (radiator)

Then ultrasonic generator is on, and waveguide tool 3 transmits ultrasonic oscillations to sound zone. Length of supporting in-bone edge low-angle of the rod-wood screw of 4 parts of the waveguide tool 3 depends to considerable extent from diameter

of process able tubular bone and amplitude of ultrasonic impact. At high levels of impact (20-30 mk) protruding part of the waveguide tool 3 decreases and at low levels of impact (5-15 mk) it can be increased. Frequency of ultrasonic impact as well can be different, depending on required directivity of acoustic impact. So, far increase of sanation efficiency marrowy channel at simultaneous introduction. In the recent research ultrasonic impact was implemented through ultrasonic apparatus "Yarus-M", with introduction through aperture of rod - the wooden screw of the waveguide to cavity marrowy channel (until it impacted against cortical layer). Sound was ejected during 3 min per day throughout 42 days from the moment of simulation of breakage, under short-term intravenous narcosis (propofol 4 mg/kg of mass of the animal body). Radiological control was performed by stationary radiological FDR AcSelerate apparatus, at 1,1 m distance from radiological pipe, with parameters: x-ray beams 40 kv, 63 ma, 200 ms. Animals were removed from the experiment after 42 days.

The evaluation of results of treatment was led from the time of stepping on operated extremity, on the time of negative clinical test which was defined on disappearance of pathological mobility at removal of the rod of the apparatus of external registration. Also the density of bone callous was evaluated basing on the pictures from the program eFilm 310T21.

The following indexes of laboratory data were considered (the level of leukocytes, ESR, alkaline phosphatase).

All experiments on animals correspond to international and national normative acts of considering laboratory animals. Animals were removed from experiment in accordance with euthanizing rules. Biological material was utilized in accordance with actual legislation.

On the basis of the experiments the following data were obtained. By using the proposed method for the activation of reparative osteogenesis by contact exposure to low-frequency ultrasonic, significant decrease in pain is observed, which allows loading the operated limb earlier – by day 8 for the main group and day 10 for the control group (p 0.0013). Clinical consolidation defined by the disappearance of pathological mobility also advanced significantly in the early period - 38 days for the control group and 41 days for the control group (p 0.0017). Consolidation results indicate that the selected method and the formation fracture osteosynthesis combination provide unfavorable conditions for the regeneration of bone tissue. In the control group only 2 animals (29%) achieved fracture consolidation, while in the basic group the use of additional stimulation led to the regeneration of bone fracture consolidation (**Figure 4**). The density of callus in the main group (162.2) was higher than in the control group (135.2) (p 0.0017).

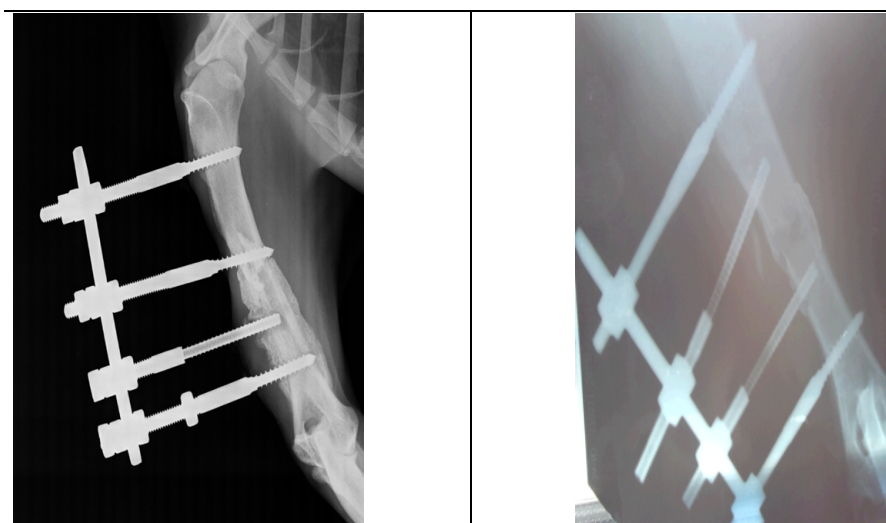

Figure 4. The roentgenograms of breakings consolidation: a) in the main group; b) in control group.

The activity of alkaline phosphatase blood reflects the activity of osteoblastic process. The main group is determined by a statistically significant increase in the activity of alkaline phosphatase on the early stages of recovery (at 3,7,10 day) (p 0.04), as previously observed normalization of the activity of the enzyme (within 35 days) (p 0.03). Postoperative wounds of all animals were healed by first intention, therefore, can only be assessed no adverse effects of ultrasound on soft tissue.

CONCLUSION

Low-frequency ultrasound exposure in contact conditions extrafocal transosseous osteosynthesis favors to accelerating the consolidation of fractures - 17% increase of the density of callus in the study group, 11% acceleration of abnormal mobility disappearance.

Low-frequency ultrasonic treatment contact promotes full consolidation of fractures in the presence of factors predisposing to a violation of bone tissue regeneration (for the main group - 100% consolidation, for the control group - full consolidation in 26% of cases).

In conditions of ultrasonic contact effects more rapid normalization of laboratory values is observed (normalization of white blood cell count period accelerated by 50%).

Ultrasound effects contribute to more rapid relief of pain (reliance on the operated limb comes up to 2 days earlier).

REFERENCES

1. Akopyan VB. Basics of interaction of ultrasound with biological objects. *Ultrasound in Medicine, Veterinary Science and the Experimental Biology*. 225.
2. Byalik EI. Features of treatment of open fractures of the long bones at victims with polytrauma. *Annals of traumatology and orthopedics*. 2002;4:3-8.
3. Klyushin NM. New technologies of treatment of patients with a chronic osteomyelitis – a result of forty years' experience of application of a method of a transosseous osteosynthesis. 2011;2:27-33.
4. Vybornov DYu. Assessment of risk factors and prediction of violations of consolidation of changes with children. *Questions of the Modern Pediatrics*. 2006;1:120.
5. Reznik LB. Effectiveness of application of ultrasound for removal of bone cement at auditing endoprosthesis replacement. *Traumatology and Orthopedics of Russia*. 2012;1:30-35.
6. Shevtsov VI. Influence of a pulsed ultrasound of low intensity on current of a reparative bone formation. *Genius of Orthopedics*. 2004;1:81-88.
7. Goodship AE. The influence of induced micro movement upon the healing of experimental tibial fractures. *J Bone Joint Surg Br*. 1985;6:650-655.
8. Ramli R. The effect of ultrasound on angiogenesis: An *in vivo* study using the chick chorioallantoic membrane. *Int J Oral Maxillofac Implants*. 2009;24:591-596.
9. Shi SF. Ultrasonically enhanced rifampin activity against internalized *Staphylococcus aureus*. *ExpTher Med*. 2013;5:25-262
10. Yang KH. Exposure to low-intensity ultrasound increases aggrecan gene expression in a rat femur fracture model. *J Orthop Res*. 1996;14:802-809.
11. Novikov AA, et al. Method of activation of reparative osteogenesis. 2016;31.
12. Novikov AA, et al. Device activation of reparative osteogenesis. 2016;33.