

Analysis of wall climbing robot

B.Vishanth¹, S.Kathiravan², S.Giri prasad³, R.Raju⁴, D.James deepak⁵

U.G. Scholars, Department of Mechanical Engineering, KPR Institute of Engineering and Technology, Arasur, Coimbatore, India^{1, 2, 3, 4}

Assistant Professor, Department of Mechanical Engineering, KPR Institute of Engineering and Technology, Arasur, Coimbatore, India⁵

ABSTRACT: A Robot is a virtual artificial agent. In practice, it is usually an electro-mechanical machine which is guided by remote, and is thus able to do tasks on its own. Conventionally, wireless controlled robots use embedded system. It can capture audio and video information from the surroundings which can be sent to a remote station through signals. Aim of the project is to be fabricating a wall climbing robot using suction force. The robot has the ability to move in vertical surfaces which is achieved by using suction pumps. The suction cups are influenced by tracked wheel mechanism. The remote operated wall climbing robot has been designed in such a way that it can fulfill all the needs of military, police and also for personal security. It has countless applications and can be used in different environments and scenarios. For instance, at one place it can be used by bomb disposal squad, while at another instance it can be used for handling mines, while another application can be to provide information in hostage situations.

KEYWORDS: Wall climbing robot, Suction force, Suction pumps, Suction cups, Tracked wheel.

I. INTRODUCTION

A. Robot

A robot is a mechanical or virtual agent, usually an electro-mechanical machine that is guided by a computer program or electronic circuitry. Robots can be autonomous or semi-autonomous and range from humanoids to industrial robots. Robotics is the branch of technology that deals with the design, construction, operation, and application of robots, as well as computer systems for their control, sensory feedback, and information processing.[1]

These technologies deal with automated machines that can take the place of humans in dangerous environments or manufacturing processes, or resemble

humans in appearance, behavior. Many of today's robots are inspired by nature contributing to the field of bio-inspired robotics. Robots have replaced humans in the assistance of performing those repetitive and dangerous tasks which humans prefer not to do, or are unable to do due to size limitations, or even those such as in outer space or at the bottom of the sea where humans could not survive the extreme environments. Mobile robots are also found in industry, military and security environments. They also appear as consumer products, for entertainment or to perform certain tasks like vacuum cleaning. Mobile robots are the focus of a great deal of current research and almost every major university has one or more labs that focus on mobile robot research. The applications of spy robot in Cleaning outer walls of high-rised buildings, Wall climbing robot was used for storage tank inspection, Spy robots can used in Military applications, Inspecting pipelines Inspection of cracks in glasses. [1]

B. Wall climbing robot

Climbing robots are useful devices that can be adopted in a variety of applications like maintenance, building, inspection and safety in the process and construction industries. These systems are mainly adopted in places where direct access by a human operator is very expensive because of the need for scaffolding, or very dangerous due to the presence of a hostile environment. A wall climbing robot should not only be light but also have large payload so that it may reduce excessive adhesion forces and carry instrumentations during navigation. Up to now a lot of research has been devoted to wall climbing robots and various types of experimental models have been already proposed. [2].

Based on locomotive mechanisms, they can generally be divided into legged mechanisms, sliding mechanisms and tracked wheel mechanisms. The

advantage of the climbing robots employing a legged mechanism is that they can overcome uneven surfaces. But, they are comparatively heavy and the control system is complicated due to the number of actuators and gait control. These problems result in low speeds with discontinuous motion. Meanwhile, the realization of the sliding mechanism is relatively simple in comparison with legged mechanisms, but its speed is also low due to discontinuous motion. Tracked wheel mechanism, can move relatively fast with continuous motion.[6]

According to the adhesion method, these robots are generally classified into four groups: magnetic, vacuum or suction cups, gripping to the surface and propulsion type. Recently, new methods for assuring the adhesion, based in biological findings, have been proposed. The magnetic type principle implies heavy actuators and is used only for ferromagnetic surfaces. The vacuum type principle is light and easy to control though it presents the problem of supplying compressed air. An alternative, with costs in terms of weight, is the adoption of a vacuum pump. The propulsion type robots are used in very restricted applications.[1]

The main mechanical structure based on engineering design, a wireless control and working principle of the tracked wheel mechanism are described, and then engineering analyses about the required suction force and the tendency of vacuum pressure in our system are presented.[3],[5]

C.Climbing robots applications

Climbing robots are mainly adopted in places where direct access by a human operator is very expensive, because of the need for scaffolding, or very dangerous, due to the presence of an hostile environment. In the last decades, different applications have been envisioned for these robots, mainly in the technical inspection, maintenance and failure or breakdown diagnosis in dangerous environments. These tasks are necessary in the outside of tall buildings, bridges, nuclear power plants or pipelines, for scanning external surfaces of gas or oil tanks and offshore platforms, for performing non-destructive tests in industrial structures, and also in planes and ships. Furthermore, they have been applied in civil construction repair and maintenance, in the prevention and fire fighting actions, in anti-terrorist actions, in cleaning operations in sky-scrapers, for cleaning the walls and ceilings of restaurants, community kitchens and food preparation industrial environments, in the transport of loads inside buildings and for reconnaissance in urban environments. Finally, their application has also been proposed in the education and human care areas. [1]

II. EXPERIMENTAL PROCEDURE

A.Design of wall climbing robot

Robot is made up of chassis, belt, wheel and tracked wheel system. On the chassis the vacuum cups are installed in the structure of climbing robot for driving. 24 suction pads and mechanical valves are installed in the outer surface of the climbing robots for driving the wheel. Rotary joints are used to prevent pneumatic tubes which link the vacuum pump. The rear axis of the wheel is connected to the brushless DC motor [2]. The main specifications of the robot are shown in table 1.

Table-1 Specifications of robot

Items	Specifications
Length	240mm
Height	75mm
Width	170mm
Wheel radius	27mm
Distance between two wheels	170mm

B.Model of wall climbing robot

In our wall climbing robot four wheels and 24 suction pads are placed. The suction pads are connected perpendicular to the belt. The belt is connected between the wheels. So there are two belts which are connected on both sides of the wheels. Each belt carries 12 suction pads, totally 24 suction pads. To prevent the climbing robot from falling or slipping, sufficient suction force able to sustain the robot weight is required. In this section, the conditions to prevent the robots from falling or slipping are addressed. There are two forces required to climb the wall. They are suction force and magnetic force where suction force is used to climb the wall. The wall climbing robot is used to climb the wall using suction pad.

Analysis of wall climbing robot

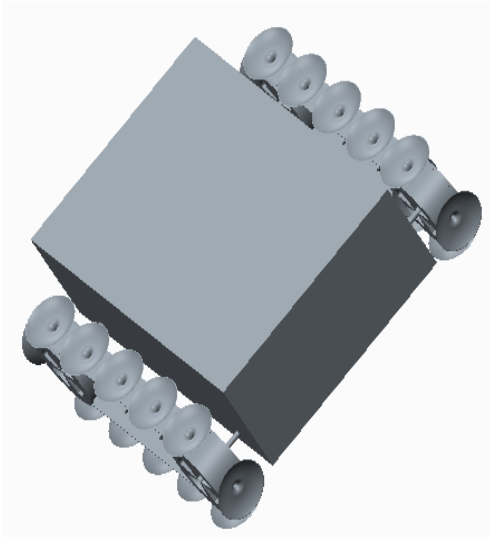

Fig-1 Model of a wall climbing robot in pro-e software

The purpose of suction pad is to hold the surface by creating low pressure zone. There are different types to create a low pressure zone. One is to create a vacuum by using vacuum pump and another one is to create vacuum by applying force to the suction pad. Normally, this has some problems that is how to remove the suction pad after that working time. If we use a vacuum pump it is easy to remove the suction pad. But, if we use force to create the vacuum area, it is difficult to remove and attach the suction pad on the wall. Here we use the second method to create the vacuum area and removing the suction pad is done by using a string. The string was connected at the end of the suction pad.

We use 24 suction pads to stick on the wall. At a time there are 8 – 10 suction pads in contact with the wall. The suction pads are connected on the belt. It is like a tracked wheel mechanism. The suction pads are connected to the wall.

C.Construction of wall climbing robot

The main parts of a wall climbing robot consists of a steering motor, suction pads and robot wheels controlled by a programmable logic controller. The steering motor is similar to the rack and pinion. Since a brushless dc motor is used the speed is reduced. The directions of wheel are changed by changing the polarity of the motor. This is the driving motor for forward and reverse motion. The forward and backward motion are achieved by changing the polarity of the motor. The speed can be varied by varying the voltage. The torque can be varied by varying the current. Here we use a 700 mAh battery with a 6V discharge capacity. Which is rechargeable. It is made up of nickel metal hydride. Since we need a remote controlled device for operating at high elevations we use a radio controller. The frequency of 27MHz is used for transmitting signals and a 9V battery is used for transmitting signals from the remote.

Copyright to IJRSET

www.ijrset.com

1295



Fig -2 Chassis

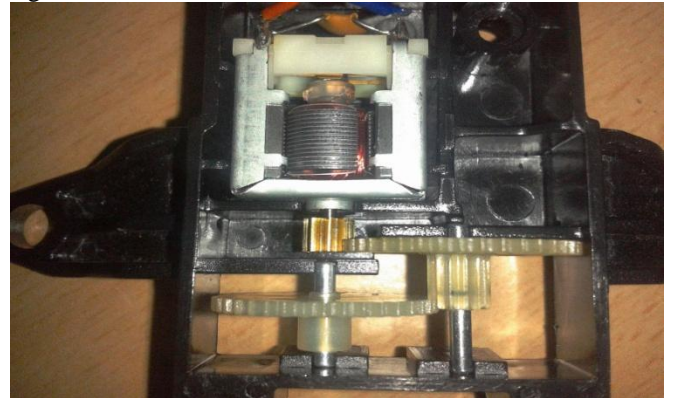

Fig -3 Steering motor

D.Working principle of tracked wheel mechanism

Here the robot employs tracked wheel is the locomotive mechanism. It can move better speed than legged mechanism and sliding mechanism so that the climbing speed of the tracked wheel mechanism has been improved. The maximum climbing speed of tracked wheel robot is 15m/min [3]. Suction pads and mechanical valves are installed in the structure of climbing robot. In this structure of robot 24 suction cups are installed, 12 are installed in one side and the other 12 are installed in the other side of the climbing robot. Each two suction cups are inter connected. If one is attached in the wall and the other is disconnected from the wall.

III. RESULT AND DISCUSSION

A. Simulation of wall climbing robot

The source used is a compressor which powers the vacuum pump. The vacuum pump is connected to the solenoid valves through PLC board. Each side has 12 suction cups. Each solenoid valve is connected to two suction cups such that it has 5 suction cups between the 2 suction cups connected to the solenoid. The pneumatic arrangement is shown in fig- 5.This way all the suction cups are connected in pair so that 1 and 7, 2 and 8, 3 and 9, 4 and 10, 5 and 11, 6 and 12 are controlled by

Analysis of wall climbing robot

individual solenoid valves. By doing so one cup is suctioned and the other one is exhausted.

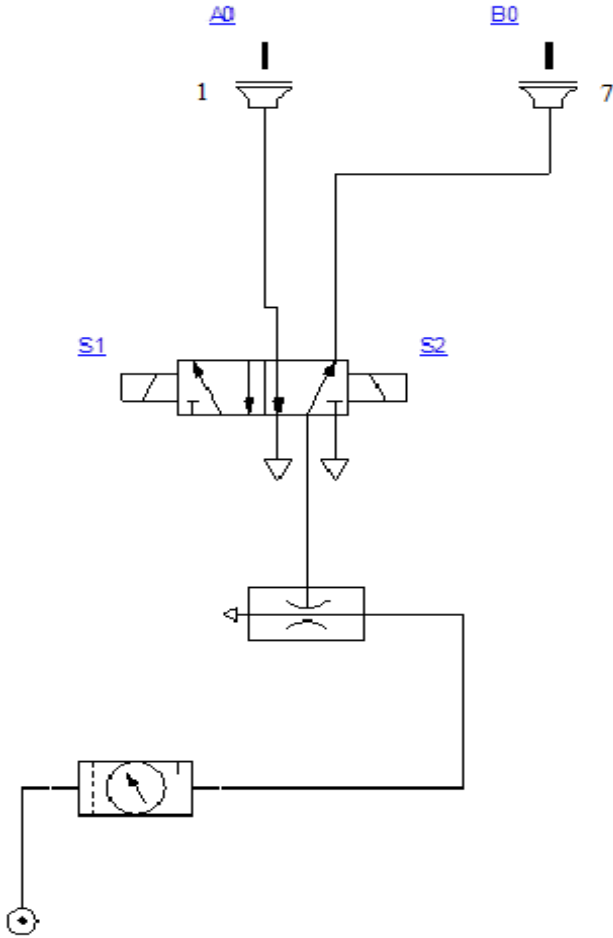

Fig-4(a) Pneumatic arrangement of suction cups

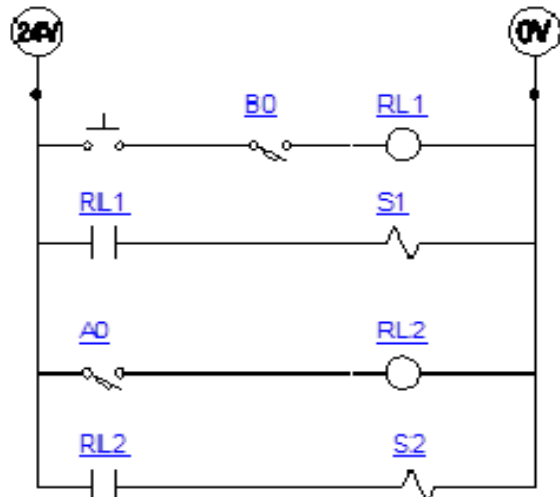

Fig-4(b) Electro-Pneumatic arrangement of suction cups
B.Examination of time(in sec)

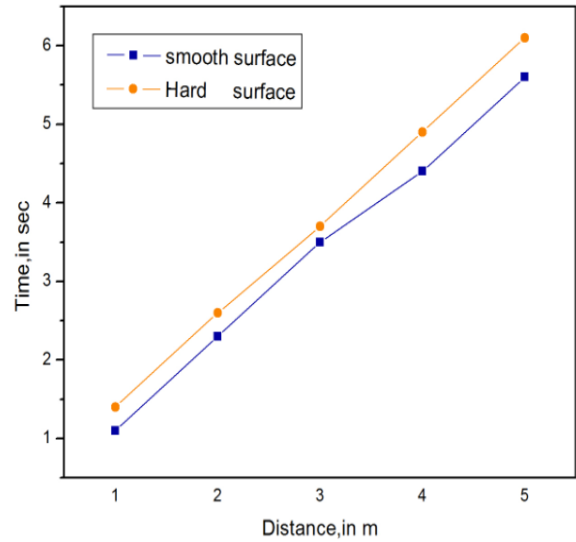

Fig-5 Expected tendency of time change

The graph between distance travelled to the time taken is illustrated in fig 5. The car motion is purely achieved by a belt mounted on the wheels. The values bound to change once the motion is achieved.

C.Examination of speed(m/s)

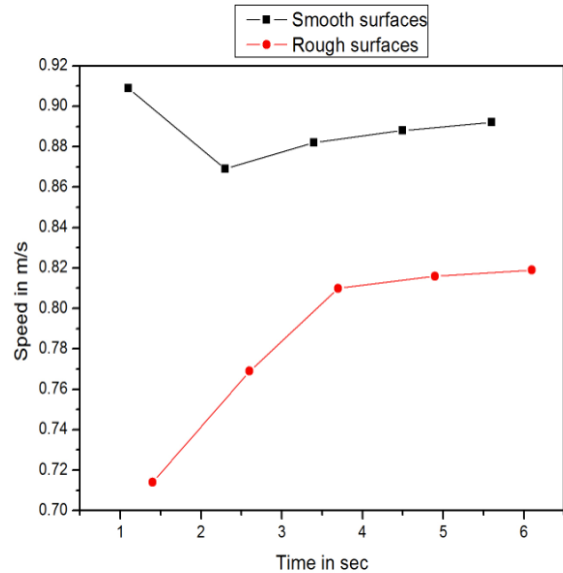

Fig-6 Expected tendency of speed changes.

The variation of speed in rough and smooth surface is illustrated in fig 6. The speeds were more even along smoother surfaces as expected. But this will change when the suction cups are placed on the wheels.

IV. CONCLUSIONS

The wall climbing robot thus is to be constructed by the use of suction pads that helps to create vacuum. The suction pads are fixed in the belt which is rotated with the help of a driving motor. The brushless dc motor is used for driving the wheel which gives forward motion for the robot. The suction pads and the robot frames are designed containing motors. The belt is to be fixed along

Analysis of wall climbing robot

the length of the wheels where the suction pads are be present and the corresponding motion of the robot is obtained. A spy camera will be fixed with the frame which is used for recording purposes and the output can be seen from a remote location.

REFERENCES

- [1] Ashish dutta, Mikell P Groover, Mitchel weiss, Nicholas G Odrey and Roger N Nagel, "Industrial robotics technology, programming and applications" published by Mcgraw hill education (india) private limited at the year (2013).
- [2] Amir Shapiro, Avishai sintov and Tomer avramovich, "Design and motion planning of an autonomous climbing robot with claws" Ben-gurion University of the negev, beer sheva 84105, israel (2011) Elsevier B.V
- [3] Choi H. R, Kang T. H, Kim H. M, Lee J. H and Ryew S. M, " A wall climbing robot with closed link mechanism", in: Proc. of the 2000 IEEE/RSJ Int. Conf. on Intelligent Robots and Systems (2000), pp. 2006 – 2011.
- [4] Berns K, Braun T, Hillenbrand C and Luksch T, "Developing climbing robots for education", Climbing and Walking Robots, Springer (2005), pp. 981–988.
- [5] Amir Shapiro, Avishai Sintov and Tomer Avramovich, "Design and motion planning of an autonomous climbing robot with claws" (2011), Vol.26
- [6] Dongmok kim, Doyoung chang, Hojoon yang, Hwang kim, Jongwon kim and Kunchan seo, Kyouhee lee, "Development of a wall-climbing robot using a tracked wheel mechanism", journal of mechanical science and technology pp. 1490~1498, (2008).