



Comparative Assessment of Transmission Sunk Cost Allocation Methods for Point of Connection Transmission Pricing Philosophy

Heramb Mayadeo¹, Dr. (Mrs) A. A. Dharme²

PG Student [Power Systems], Dept. of EE, College of Engineering, Pune, Maharashtra, India¹

Associate Professor, Dept. of EE, College of Engineering, Pune, Maharashtra, India²

Abstract: The evolution of deregulated power markets has seen a parallel evolution in transmission pricing methods and philosophies. All the transmission pricing schemes can be broadly classified into two main philosophies: point-to-point and point-of-connection (PoC). PoC philosophy charges a single rate per MW depending upon the point of connection. The philosophy though apparently simple, easy to implement and understand, implies the difficult task of fixing up PoC rates. This paper aims solely at the recovery of sunk cost, being the largest part of transmission rates and the most difficult one to allocate. The paper compares 4 different methods of sunk cost recovery viz. Power tracing, marginal participation factors, postage stamp and hybrid method.

Keywords: Point-of-connection tariff (PoC), transmission pricing methods, sunk cost.

I. INTRODUCTION

Two commonly employed philosophies for transmission pricing in the decentralized markets are: Point-to-point and Point-of-connection (PoC) tariff [1].

The point to point tariff also known as transaction based tariff is peculiar to the sale of power from a particular source to a particular consumer. Various methods like postage stamp, MW-mile and contract path methods represent this class of transmission pricing.

The PoC tariff is employed in Nordic pool. The basic principle of PoC Tariff is “*The idea of point tariff system is that the producers are paying a fee to the grid for each kWh that they pour into the grid and the end users pay a fee for each kWh that they draw off the grid. Moreover, the kilowatt-hour can be traded freely in the whole area without additional fees*”[2]. The PoC tariff depends upon the characteristics of the individual seller or buyer. The distinguishing feature is that it can be applied for both power exchange (PX) and bilateral transaction between two parties.

The most common and unsophisticated approach which was being used widely in the earlier days of deregulation is postage stamp method. In this method there is no attention paid to the actual system usage and the cost allocation is done on the basis of average system costs. The user simply pays the charge at a rate equal to a fixed charge per unit of energy transmitted within a particular utility system. What makes this pricing scheme obsolete in addition to this is its inability to accommodate congestion constraints. To introduce fairer and more transparent charges; methods needed to be technically sound and must be able to calculate rates as per actual usage of the system. This encouraged researchers to go for more complex but technically sound methods. One of the very elaborate methods is marginal participation method [3], [4]. This method is based on sensitivity factors of transmission lines and provides locational price signals as well as it can be used to allocate congestion charges.

Another power flow based method is ‘power tracing’ or ‘average participation’ method. This was proposed in 1996 almost simultaneously and completely independently by Bialek and Kirschen [5], [6]. Both the approaches are based on proportional sharing principle [7], [8]. Both of these methods determine the contribution of transmission users towards transmission usage. But, both of these methods differ in their approach towards solving the problem. Bialek’s method is based on simultaneous equations approach whereas Kirschen’s method employs ‘graph theory’. Another approach based on graph theory is proposed by Felix Wu which is considered in forthcoming analysis [9].



In Indian context the method used is a hybrid method, which is a combination of power tracing and marginal participation factors method [10].

II. METHODOLOGY USED

A. Postage Stamp (PS) Method

This is a traditionally used method by electricity companies to allocate fixed transmission charges among the users of firm transmission service. This is an ‘embedded cost’ method or ‘rolled-in cost’ method. This is the simplest and probably the crudest method as it does not require any power flow calculations and it does not account for the transmission distance and network configuration. The basic assumption of this method is; entire transmission system is used, regardless of the actual facilities that carry the transmission service. The charges are allocated on the basis of average embedded cost and the magnitude of user’s transacted power as per equation (1).

$$C_i = TTC \frac{P_{Li}}{\sum_{i=1}^n P_{Li}} \quad (1)$$

Where,

C_i - Charge allocated to i^{th} node, TTC – Total transmission cost, P_{Li} - load in MW at i^{th} bus, n - number of nodes

Apart from its only merit i.e. simplicity this method suffers numerous demerits. This method does not account for the actual system usage and/or congestion in the system. No locational pricing signals are provided by this method. Also, the user at the farthest end of the system is always at benefit since it uses the system most and pays only for the proportion of the load connected at its bus.

B. Marginal Participation Factors (MAPF) Method

This is a power flow based method and makes use of sensitivity factors and makes use of extent of use criterion to allocate charges among the system users. This method is also called as ‘areas of influence’ method in Chile and Argentina. The usage is defined as incremental i.e. the incremental change in power flow in each corridor (line) is computed for 1 MW incremental increase in load/generator at each load node. Once the power flow variation in each corridor is obtained for incremental increase in each load/generator the usage index is calculated as per equation (2).

$$U_{il} = \sum_{c, |F_l^i| - |F_l| > 0} (|F_l^i| - |F_l|) P_i \quad (2)$$

Where, F_l is the base case power flow of the corridor, F_l^i is the power flow in corridor l when load/generator at i^{th} bus is increased by 1 MW, P_i is the power consumed/generated by i^{th} load/generator respectively, U_{il} is the usage factor of i^{th} load over l^{th} corridor.

In this case only positive changes in power flow of a corridor are considered, as this is how it has been implemented traditionally wherever it is used. But, a version can be developed where negative changes in power flow are considered and are paid instead of being charged. This being a marginal method it is necessary to weight each usage factor by amount of load the unit of U_{il} becomes MW^2h .

The marginal participation factor of i^{th} load/generator over l^{th} corridor is given by equation (3).

$$MPF_{il} = \frac{U_{il}}{\sum_i U_{il}} \quad (3)$$

This method is dependent on the selection of slack bus to run the power flow. The values of participation factors change once the slack bus is changed. This is applied in Chilean and Argentinean systems where a slack bus is defined and the systems are radial with a strong load in centre and secondly line capacity limits are ignored. Otherwise more advanced technique can be used as given in [11].



C. Power Tracing or Average Participation Factors (APF) Method

1) Proportional sharing principle

‘Proportional sharing principle’ states that “the nodal inflows are shared proportionally among nodal outflows” [7]. Both the approaches of power tracing viz. simultaneous equations [5] [12] & graph theoretic [6] [9] are based on the proportional sharing principle. Graphically it is illustrated in Fig. 1

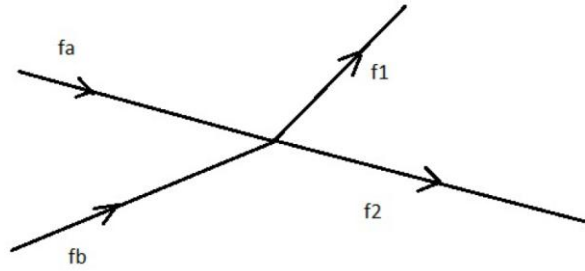

Fig.1 Proportional sharing principle

$$f_1 = f_1 \frac{f_a}{f_a+f_b} + f_1 \frac{f_b}{f_a+f_b} \tag{4}$$

$$f_2 = f_2 \frac{f_a}{f_a+f_b} + f_2 \frac{f_b}{f_a+f_b} \tag{5}$$

The assumptions made are,

- Kirchoff’s current law must be satisfied for all the nodes in the network
- Network node is a perfect mixer

2) Tracing Methods

Power tracing algorithms provide us with,

- Contribution of generators in line flows
- Contribution of loads in line flows
- Load generation interaction
- Loss allocation

The simultaneous equations approach is easy to code but requires distribution matrix inversion and which is very difficult for a large system as distribution matrix can be singular due to its sparse nature. On the other hand graph theoretic approach does not involve matrix inversion and it is very intuitive but it is difficult to code. In the forthcoming discussion graph theoretic approach is used, in particular Wu’s method is implemented. Following assumptions are made to simplify the problem,

- An AC load flow solution is available from on-line state estimation or off-line system analysis
- No loop flows are present
- The line active and reactive power flows keep constant along the line, each edge has a definite direction and the network is lossless.
- A generator has the priority to provide power to the load on the same bus
- The flows of electricity obey the proportional sharing rule

Bus-line incident matrix (BLIM) can be used to form bus-inflow-line (BILIM) and bus-out flow line (BOLIM) incident matrices respectively and determine the pure sink and pure source of the system. A pure source node is that node on which no power inflows exist. A pure sink node is one in which no power outflows exist. This method is also proposed in two versions: upstream looking algorithm and downstream looking algorithm. In this paper downstream looking



algorithm is considered. Both the algorithms are dual of each other and give same results. A very lucid explanation and procedure for downstream looking algorithm is given in [13], as follows,

- Start with a node which has highest. This node is called as a pure source. A pure source is defined as a node on which only real power outflows exist and there are no inflows of real power. Delete this node and also remove the lines connected to this node. Carry forward the flows on these lines to the receiving end nodes as generation contribution of generator on pure source node. Load on this bus is considered as an additional outflow.
- Once the pure source and corresponding lines have been deleted, search for a new pure source. Delete this node and also remove the lines connected to this node. Carry forward the flows on these lines to the receiving end node as generation contribution of generator on pure source node. This is done on proportional sharing basis. Load is considered as an additional outflow on that node
- Repeat this process till all pure sources are exhausted. That means, the nodes which are left are the pure sinks. A pure sink is a node on which only inflows exist. A system can have multiple pure sinks

This downstream tracing (DSTR) algorithm is applied to obtain the contribution factors of individual generators to line flows and loads. The state variable in DSTR is the net generator power. Following matrices are calculated

- Extraction factor matrix of lines and loads from bus total passing power
- The other is contribution factor matrix of generators to bus total passing power

The product of these two matrices constitutes the contribution factors of generators to line flows and loads.

Extraction factors of lines from bus total passing power,

$$P_l = A_l P \tag{6}$$

where, P_l is the vector of line power, P is the vector of bus passing power in the bus sequence of downstream tracing algorithm & extraction factor matrix of lines A_l is calculated as follows

$$(A_l)_{line\ j, bus\ i} = \frac{line\ j\ 's\ power\ flow}{bus\ i\ 's\ total\ passing\ power\ P_i} \tag{7}$$

Similarly, extraction matrix of loads A_L is calculated as

$$(A_L)_{ij} = 0 \quad i \notin net\ load\ bus \tag{8}$$

$$= \frac{net\ load\ on\ bus\ i}{P_i} \quad i \in net\ load\ bus \tag{9}$$

The extraction factor matrix of lines and loads (combined) is obtained as follows

$$A = \begin{bmatrix} A_l \\ A_L \end{bmatrix} \tag{10}$$

The matrix A has one and only one non-zero element in each row and the sum of elements in every column is one.

Contribution factors of generators to bus total passing power,

The contribution factor matrix B is defined as,

$$P = B P_G \tag{11}$$

Where, P_G is the vector of generator power. The matrix B is formed row by row. The elements are calculated as follows

$$\begin{aligned} B_{bus-i, bus-k} &= 1 \quad (k = i, k \in net\ generation\ bus) \\ &= 0 \quad (k = i, k \neq net\ generation\ bus) \\ &= 0 \quad (k > i) \\ &= 0 \quad (k < i, k \neq net\ generation\ bus) \end{aligned} \tag{12}$$



$$= \sum_{lj \in i} (A_{lj-m} B_{m-k}) \quad (k < i, k \in \text{net generation bus})$$

Where,

$k > i$ means k is downstream bus of i & hence all corresponding elements are 0 as they do not affect the passing power of the upstream bus.

$k < i$ means k is an upstream bus of i .

$lj \in i$ means line j is inflow of bus i .

A_{lj-m} is the unique nonzero element corresponding to line in matrix A_l with bus m as its upstream terminal. B_{m-k} is the element in matrix already calculated which represents the contribution of generator to the total injection power of bus m . The product of above two terms represents the contribution of generator k to the total injection power of bus through line (from bus m to bus k).

The contribution factors of individual generators to line flows and loads are calculated as follows,

$$P_l = A_l P = A_l B P_G = K_{lG} P_G \quad (13)$$

$$P_L = A_L P = A_L B P_G = K_{LG} P_G \quad (14)$$

D. Hybrid Method

Hybrid method is used in India for calculation of point charges. This method combines the features of above mentioned methods. MAPF method is slack bus dependent; if slack bus is changed the factors also change. The algorithm for hybrid method can be explained in following steps,

- Run the tracing algorithm on the system
- From the load generator interaction find out which generators are contributing power to which load and the proportion in which they supply that particular load
- Increment the load at each node by 1MW one after the other
- After the load is increased, ask the relevant to supply the incremental load in the same proportion generators as given by load generator interaction in step 2
- Calculate marginal participation factors with remaining steps same as that of normal MAPF method

In this method, essentially we define a number of slack buses by asking relevant generators to supply the incremental load in a proportion calculated from power tracing algorithm. This removes the problem of slack bus dependency of normal MAPF method.

III. CASE STUDY

Throughout this paper the system taken as a reference is an IEEE 30 bus modified system. All the considered methods are implemented on this modified system presented in Fig. 2. The single line diagram of the system is as follows,

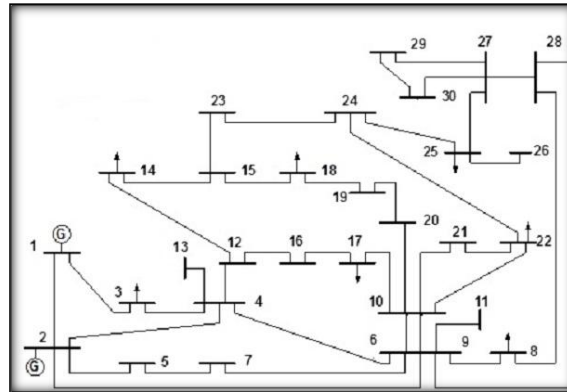

Fig.2 Modified IEEE 30 bus system

The system data is given in appendix D of [8]. The assumptions made are,

- The total sunk cost of the transmission network to be recovered is considered Rs. 10, 00,000/-
- Cost of each line is proportional to its reactance (X)
- Half of the cost will be recovered from loads and half will be from generators
- System is considered as lossless (R is neglected for using DC power flow)
- Only sunk (fixed) cost is considered

IV. RESULTS

The nodal charges in Rs/MW obtained after implementing the three discussed methods are as follows

TABLE 1
 Nodal charges in Rs/Mw for loads

Load Node	Load	Average Participation	MAPF	Hybrid	PS
2	21.7	45.31	32.28	50.80	1767.41
3	2.4	374.26	1025.11	958.28	1767.41
4	7.6	271.24	390.11	318.75	1767.41
5	94.2	283.62	60.60	47.39	1767.41
7	22.8	369.37	340.55	288.92	1767.41
8	30	729.56	212.30	154.82	1767.41
10	5.8	1558.22	3121.55	2222.01	1767.41
12	11.2	615.64	859.85	674.26	1767.41
14	6.2	2715.73	2819.54	2155.06	1767.41
15	8.2	1884.24	2055.10	1522.12	1767.41
16	3	2657.81	5117.43	4091.76	1767.41
17	9	3774.90	2289.87	1700.99	1767.41
18	3.2	4297.40	6481.04	4059.32	1767.41
19	9.5	4526.91	2483.21	1424.60	1767.41
20	2.2	3128.96	11644.33	6320.92	1767.41
21	17.5	1994.07	1265.25	1761.76	1767.41
23	3.2	4794.92	7046.79	9724.43	1767.41
24	8.7	8810.71	3236.94	4502.17	1767.41
26	3.5	10594.67	15901.67	18999.21	1767.41
29	2.4	6102.88	25527.72	29490.51	1767.41
30	10.6	9251.24	8967.80	9865.03	1767.41



TABLE 2
 Nodal charges in Rs/Mw for loads

Gen Node	Generation (MW)	Average Participation (Power Tracing)	MAPF	Hybrid	PS
1	242.9	944.67	1449.57	944.67	1767.41
2	40	6232.92	611.76	2698.50	1767.41

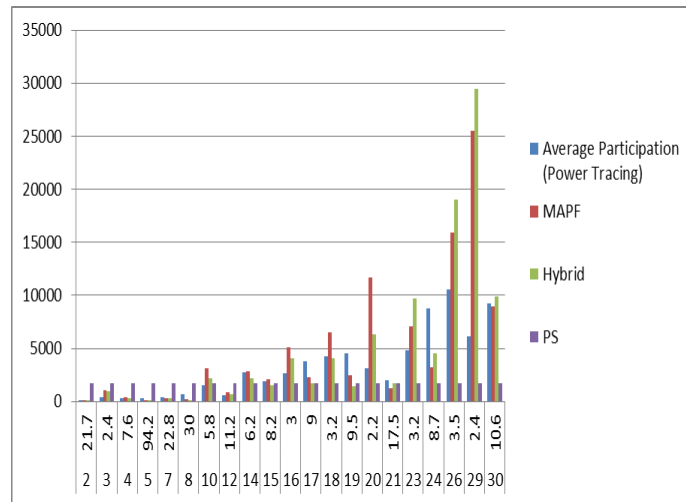

Fig.3. Comparison of nodal charges for loads

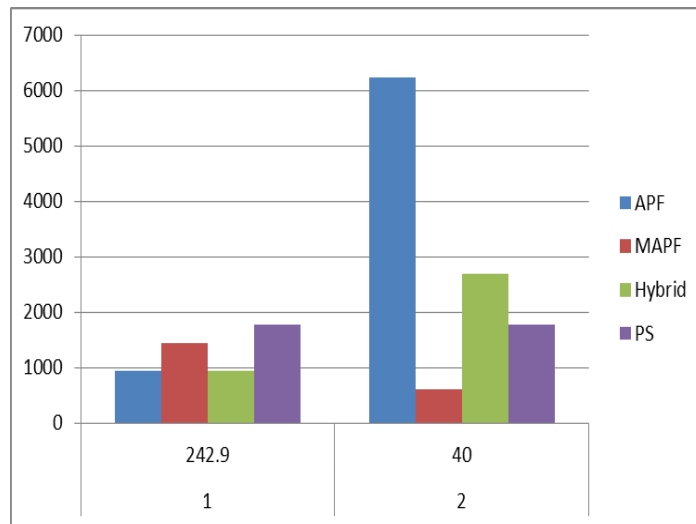

Fig.4. Comparison of nodal charges for generators

From table 1, 2 and fig. 3, 4 it is observed that the locational price signals are best provided by APF (Power tracing) method as it considers the system usage and nodal demand values, on the other hand MAPF method uses sensitivity of a load/generator for a particular line flow and hence the charges vary as per the sensitivity and not the actual usage of system and fail to provide good locational signals. The hybrid method being a combination of both power tracing and MAPF method provides pricing signals in accordance with the sensitivity and the location. PS method totally fails to provide any kind of locational signals.



TABLE 3
 Demand network use rate statistics

	Average Participation (Power Tracing)	MAPF	Hybrid	PS
Max (Rs./MW)	10594.67	25527.72	29490.51	1767.41
Min (Rs./MW)	45.31	32.28	47.39	1767.41
Avg (Rs./MW)	3275.32	4803.76	4777.77	1767.41
σ (Rs./MW)	3155.58	6329.71	7273.69	0.00
Volatility (%)	96%	132%	152%	0%
Cost Recovery Factor (%)	98%	96%	96%	100%

TABLE 4
 Generation network use rate statistics

	Average Participation (Power Tracing)	MAPF	Hybrid	PS
Max (Rs./MW)	6232.92	1449.57	2698.50	1767.41
Min (Rs./MW)	944.67	611.76	944.67	1767.41
Average (Rs./MW)	3588.80	1030.67	1821.59	1767.41
σ (Rs./MW)	3739.36	592.42	1240.14	0.00
Volatility (%)	104%	57%	68%	0%
Cost Recovery Factor (%)	96%	75%	67%	100%

From table 3, APF method has lesser rate volatility (defined as the ratio of σ and average) for loads as compared to MAPF and hybrid method whereas table 4 shows exactly opposite behaviour in case of generators. Similar contrast is observed in case of σ values in case of loads and generators. This indicates that APF method is a better indicator for network usage with lesser volatility in case of wide spread loads. In PS method no network usage is indicated since system usage is considered on averaged basis which also causes pancaking of charges.

The cost recovery factor (ratio of total cost recovered to total sunk cost) is 100% for postage stamp method but according to DC power flow results line numbers 16 (from bus 12 to bus 13) and 13 (from bus 9 to bus 11) have zero power flow hence zero usage. Hence whether to recover the cost of these unused lines from existing customers or not becomes the policy related issue. But, APF method, being usage based method has less than 100% cost recovery factor indicating that only the cost of actual usage of network has been recovered from existing users. From table III and IV it is evident that APF method is the best method as far as the actual usage based cost recovery is considered. MAPF & hybrid methods have a very poor cost recovery factor for generators.

V. CONCLUSION

The system under consideration is characterized by concentration of generation at one end and loads spread throughout the length of the system, hence it is almost a radial system.

From locational price signals point of view APF method generates moderate signals as it considers only actual system usage whereas MAPF & hybrid methods also include sensitivity factors (GSDFs). From volatility (defined as ratio of σ and average) point of view PS method is best but it does not consider anything other than nodal demand in MW hence it is unjust for users with limited usage of transmission network.

The cost recovery factor (ratio of actual cost recovered to the total sunk cost to be recovered) is best for PS (100%), but the cost allocation is unjust. Whereas, APF method has better cost recovery factor for both generators and loads (98% & 96% resp.) where as other methods have poor cost recovery factor for generators. This is in accordance with the



power flow results, as line numbers 13 (from bus 9 to 11) and 16 (from bus 12 to 13) have zero power flow the usage of those lines is zero. Hence whether to recover the cost of these unused lines from existing customers remains a policy issue and out of the scope of this paper.

Considering above discussion, for a network having similar characteristics to that of the system under consideration APF method is most suitable for fixed cost allocation. As it reflects actual network usage, creates moderate price signals, moderate cost recovery and avoids pancaking.

ACKNOWLEDGEMENTS

The authors would like to thank Prof. Dr. Abhijit Abhyankar (Assistant Prof., IIT Delhi) for his invaluable guidance and support. Without his involvement the work would not have been completed.

REFERENCES

- [1] Roy, A.; Abhyankar, A.R.; Pentayya, P.; Khaparde, S.A., "Electricity transmission pricing: tracing based point-of-connection tariff for Indian power system," Power Engineering Society General Meeting, 2006. IEEE, pp.8
- [2] Point tariff system [online] Available:<http://www.nordpoolspot.com/mwginternal/de5fs23hu73ds/progress?id=wNnwTKPYG>
- [3] F. J. Rubio-Od'eriz and I. J. P. Arriga, "Marginal pricing of transmission services: A comparative analysis of network cost allocation methods," IEEE Transactions on Power Systems, vol. 15, pp. 448–454, February 2000.
- [4] I. Perez-Arriaga, F. J. Rubio, J. F. Puerta, J. Arceluz, and J. Marin, "Marginal pricing of transmission services: an analysis of cost recovery," IEEE Transactions on Power Systems, vol. 10, no. 1, pp. 546–553, 1995
- [5] J. W. Bialek, "Tracing the flow of electricity," IEEE Proc.-Gener. Transm. Distrib., vol. 143, pp. 313–320, July 1996.
- [6] R. Allen, D. Kirschen, and G. Strbac, "Contribution of individual generators to loads and flows," IEEE Transactions on Power systems, vol. 12, pp. 52–60, Feb 1997
- [7] M. Shahidehpour, H. Yamin, and Z. Li, *Market Operations in Electric Power Systems: Forecasting, Scheduling and Risk Management*, Wiley-Interscience, 2002.
- [8] Z. Jing and F. Wen, "Discussion on the proving of proportionality sharing principle in electricity tracing method," IEEE/PES Transmission and Distribution Conference & Exhibition: Asia and Pacific Dalian, China, pp. 1–5, 2005.
- [9] F. F. Wu, Y. Ni, and P. Wei, "Power transfer allocation for open access using graph theory: Fundamentals and applications in systems without loop flow," IEEE Transactions on Power Systems, vol. 15, pp. 923–929, August 2000.
- [10] CERC (2010), Formulating pricing methodology for inter-state transmission in India attachment-I to the central electricity regulatory commission (sharing of transmission charges and losses) regulations [online], available at: <http://www.nordpoolspot.com/mwg-internal/de5fs23hu73ds/progress?id=wNnwTKPYG>
- [11] H. Rudnick, R. Palma, and J. Fernandez, "Marginal pricing and supplement cost allocation in transmission open access," IEEE Transactions on Power Systems, vol. 10, no. 2, pp. 1125–1132, 1995
- [12] J. Bialek, "Topological generation and load distribution factors for supplement charge allocation in transmission open access," IEEE Transactions on Power Systems, vol. 12, no. 3, pp. 1185–1193, 1997.
- [13] A. R. Abhyankar, S. A. Khaparde, and C. V. Dobariya, "Tracing the flow of electricity - power flow tracing simplified"