



Design, Implementation of High Speed ARM Processor Based Data Acquisition and Control System Prototype

R. Lakshmi Narayana, Dr. K. Nagabhushan Raju

Research scholar, Dept. of Instrumentation, Sri Krishnadevaraya University, Ananthapuramu, Andhra Pradesh, India¹

Professor, Dept. of Instrumentation, Sri Krishnadevaraya University, Ananthapuramu, Andhra Pradesh, India²

Abstract: The ethernet controlled devices have its own demand and application with fast development in technology. The system of data acquisition and control is designed based on the Cortex-M3 processor in the research activity. The proposed activity is designed to add security issue to any general premises. It realizes an embedded web server, which enables data acquisition and status monitoring with the help of any standard web browser. In this paper, device control and data acquisition system is based on embedded ethernet platform support is designed. The processor has inbuilt ethernet to optimizing the hardware complexity of the system. A data can be transmitted transparently through the internet it is built into cortex-m3 processor to the remote end desktop computer. This design has the advantage of low power consumption, cost-effective, easily realized, stable and reliable transmission.

Keywords: ARM cortex-m3, Embedded web server, Remote monitoring.

I. INTRODUCTION

An embedded system is a special computer system that is based on computer technology, focuses on application, software and hardware customizable, suitable for the strict requirement of application system on function, reliability, cost, volume and power. Embedded ethernet is a single-chip to implementing the ethernet network standard. Simply put, by embedding ethernet onto a device, it has the capability to communicate via ethernet without using a computer. But most of the embedded systems are used independently at current stage, CAN, RS-232 and RS-485 are the most commonly used technologies to deal with the communication between multiple microprocessors in industrial control fields and has the disadvantages such as low transmission rate, limited coverage, relatively less communication protocols, etc., which cause it very difficult to perform flexible remote access and management. The ethernet (IEEE 802.3) is the most mature and widely used LAN technology, connecting the embedded device to the network device such as Hub, switch thus realizing a flexible real time control and monitoring has already become an inevitable development trend of embedded technology. Combine the mature technology of Web with the embedded and fully utilize the advantages of both [6]. In this research paper, the design and implementation of a remote monitoring and control system is based on ARM cortex-M3 processor [2]. The processor board which has an ethernet port to send the sensor parameter values to remote computer. The conventional hardware functioning logic of sensors and control devices is incorporated with the Texas Instruments device lm3s9b96 [3]. This processor is programmed to interface with the remote console computer WEB page, to monitor the condition of the sensors, and to produce control actions to ensure device's safety. The user select buttons for sensor have been interfaced to the processor through analog to digital converters and device controls are digital I/O lines. The monitoring and controlling functionalities [1] have been realized with Keil-4 (IDE) software targeted onto ARM Cortex-M3 based device are connected using a crossover ethernet cable RJ45. On the transmission side, user-entered data is compiled into an IEEE 802.3 frame; on the reception side, data is extracted from the frame and displayed through the embedded web page.

II. SYSTEM DESIGN

The Stellaris ethernet controller consists of a fully integrated media access controller (MAC) and network physical (PHY) interface. The ethernet controller conforms to IEEE 802.3 specifications and fully supports 10BASE-T and

International Journal of Advanced Research in Electrical, Electronics and Instrumentation Engineering

(An ISO 3297: 2007 Certified Organization)

Vol. 2, Issue 10, October 2013

100BASE-TX standards. The ethernet controller is functionally divided into two layers: the media access controller (MAC) layer and the network physical (PHY) layer. These layers correspond to the OSI model layers 2 and 1, respectively. The CPU accesses the ethernet controller via the MAC layer. The MAC layer provides transmits and receives processing for ethernet frames. The MAC layer also provides the interface to the PHY layer via an internal media independent interface (MII). The PHY layer communicates with the ethernet bus.

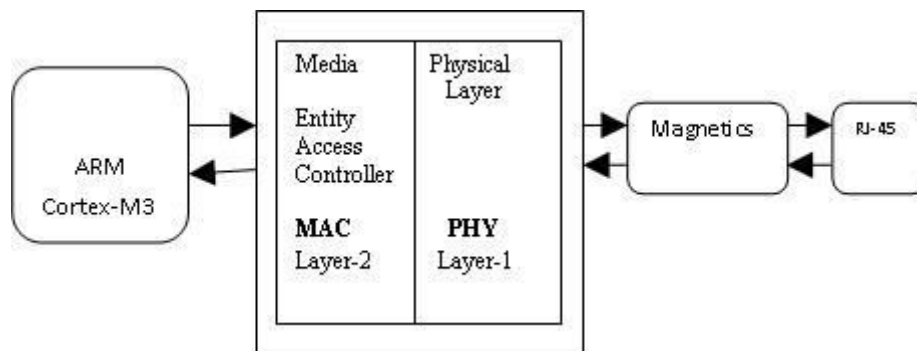

Fig. 1 Block diagram of internal structure of ethernet controller

Here, lm3s9b96 board with RJ-45 connector interface is presented. Implementation of a single-chip ethernet, the microcontroller is to incorporate the ethernet MAC, and PHY on a single chip, thereby eliminating more external components. This enables the MAC and PHY to be matched and reduces the overall pin count and chip footprint. It can also lower power consumption, especially if power down modes is implemented. The MAC is the media access controller. The Ethernet MAC is defined by the IEEE-802.3 Ethernet standard. It implements a data-link layer. The latest MACs support operation at both 10 Mbits/s and 100 Mbits/s. This crop typically implements the MII. The Media Independent Interface (MII) is an Ethernet industry standard defined in IEEE 802.3. It consists of a data interface and a management interface between a MAC and a PHY shown in Fig. 1. The data interface consists of a channel for the transmitter and a separate channel of the receiver. Each channel has its own clock, data, and control signals. The MII data interface requires a total of 16 signals. The management interface is a two-signal interface, one signal for clocking and the other for data. With the management interface, upper layers can monitor and control the PHY. The PHY is the physical interface transceiver. It implements the physical layer. PHY incorporates a significant amount of analog hardware, while the MAC is typically having all digital components. The chip footprint and the mixed analog/digital architecture are why MACs were first incorporated in microcontrollers, leaving the PHY off-chip. More flexible, higher-density chip technology has allowed both the MAC and PHY to reside on the same chip.

Data transmission requires a brief discussion of the OSI Model, which consists of seven layers in order from the top layer to the bottom layer: A computer network protocol stack consists of the modules involved with networking. The Fig.2 shows a Network Protocol Stack for a computer that connects to an Ethernet network and supports common Internet protocols. At the bottom of the stack is the hardware interface to the network cable. The top of the layer is application layer is the top layer of the OSI (Open System Interconnectivity) server layer model. This layer handles issues like network transparency, resource allocation and problem partitioning. The application layer is concerned with the user's view of the network (e.g. Formatting electronic mail messages). The presentation layer provides the application layer with a familiar local representation of data independent of the format used on the network. Transmission control protocol, and pronounced as separate letters, TCP is one of the main protocols in TCP/IP networks. Whereas the IP protocol deals only with packets, TCP enables two hosts to establish a connection and exchange streams of data. TCP guarantees delivery of data and also guarantees that packets will be delivered in the same order in which they were sent. The number of layers a message passes through can vary. For some messages that travel only within a local network, the application layer can communicate directly with the Ethernet driver.

International Journal of Advanced Research in Electrical, Electronics and Instrumentation Engineering

(An ISO 3297: 2007 Certified Organization)

Vol. 2, Issue 10, October 2013

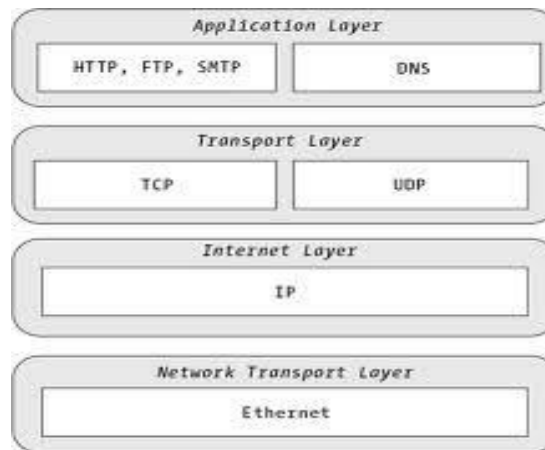

Fig. 2 Block diagram of Network Protocol Stack

In ethernet networks, a unique hardware address identifies each interface on the network [4]. The IP addresses are more flexible because they aren't specific to a network type. A message that uses IP can travel through different types of networks, including ethernet, token-ring, and wireless networks, as long as all of the networks support IP. A communication in a local network that doesn't use TCP or UDP may not require IP. Messages that travel on the internet must use the IP. Messages that use the internet protocol can also use the user datagram protocol (UDP) or the transmission control protocol (TCP) to add error checking or flow-control capabilities. The Cortex-m3 Lm3s9b96 microcontroller board uses an inbuilt feature of real-time industrial connectivity, with a 10/100 Ethernet MAC/PHY. An application often has a user interface that enables users to request data from a computer on the network or provide data to send on the network. It uses a standard protocol such as the hypertext transfer protocol (HTTP) for requesting and sending Web pages.

III. HARDWARE DESIGN

The system mainly composed of ethernet interface is an inbuilt core part of the design, in which the ARM Cortex-M3 chip (Lm3s9b96) is used. The microcontroller core is operating at up to 80 MHz, with 256 kB flash, 96 kB SRAM, a 32-ch DMA, a 32-bit external peripheral interface, a 16MHz internal precision oscillator, and ROM preloaded with the StellarisWare Driver Library, Boot Loader, AES encryption lookup tables, a cyclical redundancy check (CRC) function, and SafeRTOS kernel for general RTOS and safety critical applications. The LM3S9B96 also features real-time industrial connectivity, with a 10/100 Ethernet MAC/PHY, 2 CAN controllers, USB 2.0 Full Speed OTG/Host/Device, 2 SSI / SPI controllers, 2 I2C interfaces, an I2S interface, and 3 UARTs, as well as hardware-assisted support for synchronized industrial networks utilizing the IEEE 1588 Precision Time Protocol (PTP). The LM3S9B96 microcontroller have advanced motion controls, including 8 motion-control PWM outputs with dead-band, two quadrature encoder inputs for precise position monitoring, and 4 fault protection inputs for low-latency shutdown. The microcontroller also features intelligent analog capability, including 3 analog comparators and 16 channels of highly accurate 10-bit analog-to-digital conversion - with the ability to sample two channels simultaneously at speeds of 1M samples per second. Finally, it provides 16 digital comparators, a 24-bit systick timer, four 32-bit or eight 16-bit general-purpose timers, 2 watchdog timers, a low drop-out voltage regulator so that only one supply voltage is required, brownout reset, power-on reset controller, and up to 65 GPIOs [3]. On the LM3S9B96 board have inbuilt Ethernet interface module is provided and the collected data upload to a PC via Ethernet interface. In the figure 5 shows the hardware interfacing of external sensors on ADC and GPIO single connector and JTAG interface connector for debugging in the ARM Cortex-M3 microcontroller board.

International Journal of Advanced Research in Electrical, Electronics and Instrumentation Engineering

(An ISO 3297: 2007 Certified Organization)

Vol. 2, Issue 10, October 2013

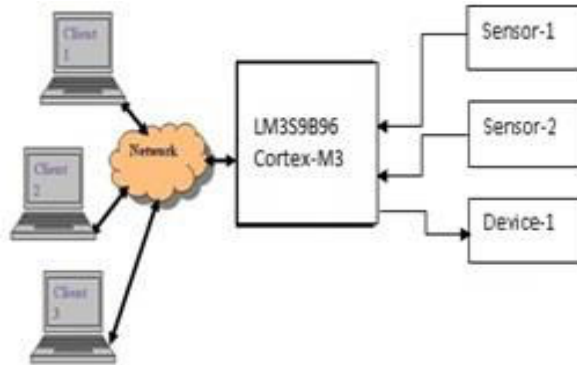

Fig. 3 Block diagram of monitoring and control system

In the fig. 3 shows the functional blocks of the proposed system. ARM cortex-m3 microcontroller is used to control a lamp and monitor a passive infra red (PIR) sensor for motion detection. A door opening Sensor and a Temperature sensor has also been integrated to enable its usage in other applications. The PIR sensor is a pyroelectric device that detects motion by measuring changes in the infra-red levels emitted by surrounding objects. This motion can be detected by checking for a high signal on a single I/O pin, in the current development. And controlling the devices we are using ULN2003 relay driver is for current amplification [7].

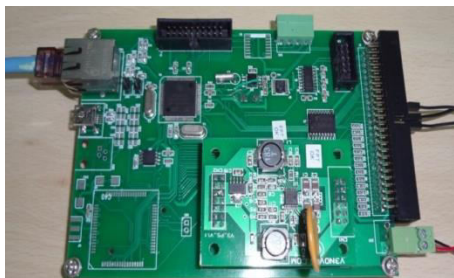

Fig. 4 A Photograph of ARM Cortex-M3 Microcontroller board

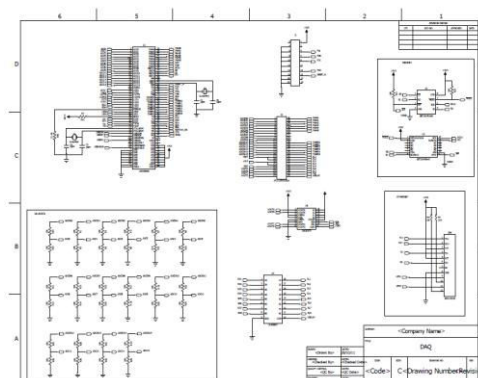

Fig. 5 Schematic circuit of ARM Cortex-M3 Microcontroller board

IV. SOFTWARE DESIGN

The Software is implementing in embedded C programming language for controlling and monitoring events, reside in ARM microcontroller. The figure 6 shows the flow of software running on the target system. To compile the designed

International Journal of Advanced Research in Electrical, Electronics and Instrumentation Engineering

(An ISO 3297: 2007 Certified Organization)

Vol. 2, Issue 10, October 2013

program produce a mapping file this can load down on to target board. When running on PC, Keil can compile memorizer directly and accede to BIOS during compiling the user program. With the development of network technology, the TCP / IP protocol has been written into the embedded system, as a result, embedded system becomes to embedded web system, corresponding to that controller of embedded system turns into a miniature network server. Until then the seamless link of bottom equipment with Internet becomes true and the remote monitoring is realized indeed. LM3S9B96 controller has installed TCP/IP protocol, so it is easy to realize connecting to the Internet.

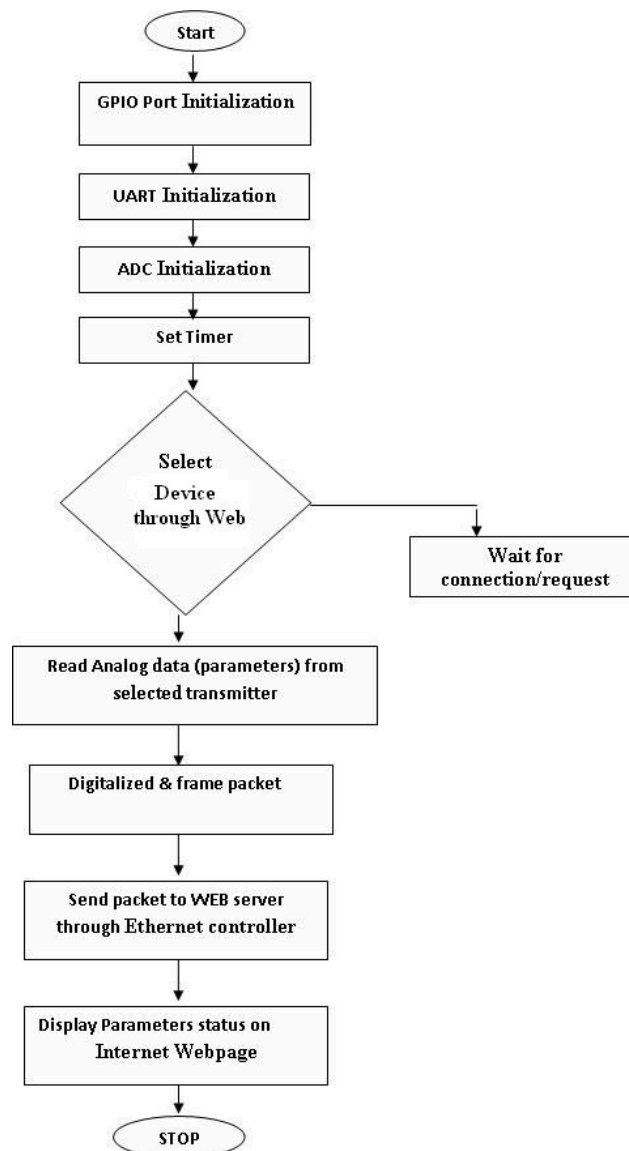

Fig. 6 Flow chart of system software

The figure 6 shows the flow of software running on the target system. To compile the designed program produce a mapping file this can load down on to target board. When running on PC, Keil can compile memorizer directly and accede to BIOS during compiling the user program. With the development of network technology, the TCP / IP protocol has been written into the embedded system, as a result, embedded system becomes to embedded web system, corresponding to that controller of embedded system turns into a miniature network server. Until then the seamless link of bottom equipment with Internet becomes true and the remote monitoring is realized indeed. LM3S9B96 controller has installed TCP/IP protocol, so it is easy to realize connecting to the Internet.



International Journal of Advanced Research in Electrical, Electronics and Instrumentation Engineering

(An ISO 3297: 2007 Certified Organization)

Vol. 2, Issue 10, October 2013

V. RESULTS AND DISCUSSIONS

The proposed system for remote monitoring and control of devices has been developed. The networking TCP/IP protocol is implemented to establish communication between embedded web server and the remote client. The purpose of the remote supervisory controller is to improve the performance of the system and to reduce the manual burden. The Stellaris Finder software tool is used to find the IP address, MAC address, Client IP and name of the application running on the device. Type the IP address in URL on any standard Web browsers that can find the web page and checks the sensor values and I/O controls. In the figure.7, ADC channels 1 to 8 are connected to the corresponding sensors. On the left side of the webpage has a Miscellaneous Settings which consists of IP address and port settings. This sample page has a relay control option which is uses to control the electrical/electronic devices connected to target board. For every 10 seconds, the sensor's data values are updated.

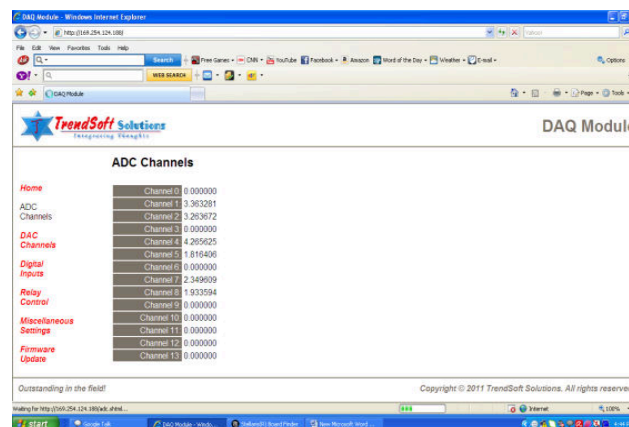

Fig. 7 Screenshot of web page for displays sensors data

VI. CONCLUSION

The Remote monitoring and controlling system based on web technology for embedded devices is designed and implemented in this research project. The RMC system adopts Browser/Server mode and realizes the interconnection of embedded devices like ARM Processor target board. Therefore, remote users can access, control and manage the embedded devices [ARM processor through remote monitoring and control devices] using a standard Web browser over the internet. It has many advantages regarding small size, data logger, system maintenance, longer work time and stable performance. It is applicable to various fields like industrial control, industrial automation, medical instruments and vice versa.

REFERENCES

- [1] Wang Jing, He Huiming, ARM-based Embedded Video Monitoring System Research, 2010 IEEE, 978-1-4244-5540.
- [2] ARM Cortex-M3 Processor reference manual; http://infocenter.arm.com/help/topic/com.arm.doc.ddi0337e/DDI0337E_cortex_m3_r1p1_trm.pdf Peterson, L. L. 1993.
- [3] Stellaris Microcontroller Device LM3S9B96 Data sheet; <http://www.ti.com/lit/ds/symlink/lm3s9b96.pdf>.
- [4] Fred Halsall, Data communication, Computer Networks and Open Systems [M]. Beijing: Machinery Industry Press, 2004, pp.572-580.
- [5] Keil-4 IDE User manual <http://www.keil.com/support/man/docs/uv4/>.
- [6] Srinivas Raja .B et al. "Design of web based remote embedded monitoring system". International Journal of Technology and Engineering Systems (IJTES), Jan-March 2011-Vol.2.No.2.
- [7] Lakshmi Narayana R et al., "An Embedded Web based Real Time Application for Remote Monitoring & Controlling of MST RADAR Transmitters" (2012), *Sensors & Transducers Journal* , Vol.136, Issue 1, January 2012, pp.96-104, ISSN 1726-5479.

BIOGRAPHY



R. Lakshmi Narayana obtained his MSc. degree in Electronics from Sri Krishnadevaraya University, Ananthapuram, A.P. India. He has been actively working on the Embedded Systems. His current research interests on Ethernet based Industrial real time controlling systems.