

# Energy Management Converter With A Flyback Snubber Fed Drive For Hybrid Electric Vehicle

Divya K.Nair<sup>1</sup>, Elizabeth Rajan<sup>2</sup>, K. Radhakrishnan<sup>3</sup>

M.Tech scholar, Dept of EEE, AmalJyothi College of Engineering, Kanjirappilly, India<sup>1</sup>

Assistant professor, Dept of EEE, AmalJyothi College of Engineering, Kanjirappilly, India<sup>2</sup>

Professor, Dept of EEE, M A College of Engineering, Kothamangalam, India<sup>3</sup>

**Abstract:** Nowadays energy management converter for electric drives are commonly being used for electric vehicles applications, due to various advantages, such as: nearly zero emission and energy recovery during braking operation. To fulfill these requirements converters with bidirectional power flow capabilities are required to connect the battery to the dc link of the motor drive system. A hybrid electric vehicle is required to function in three different modes namely: acceleration mode, normal (steady-state) mode and braking (regenerative) mode. In the present work open loop and closed loop operation of bi-directional dc-dc full bridge converter with a flyback snubber feeding a dc motor and its energy recovery due to regenerative braking has been demonstrated. The simulations are carried out using Simulink/MATLAB 7.6.0 (R2009b) package.

**Keywords:** Flyback snubber, full-bridge bidirectional converter, Hybrid electric vehicle

## I. INTRODUCTION

Large numbers of automobiles around the world has caused and continue to cause serious problems in environment and human life. Electric Vehicles (EVs), Hybrid Electric Vehicles (HEVs) and Fuel Cell Electric Vehicles (FCEVs) have been typically proposed to replace conventional vehicles in the near future. The inherent flexibility of HEVs makes them suited for personal transportation and military applications.

In renewable dc-supply systems, batteries are usually required to back-up power for electronic equipment. Their voltage levels are typically much lower than the dc-bus voltage. Bidirectional converters for charging/discharging the batteries are therefore required. Isolated bidirectional full bridge dc-dc converter has many advantages compared to traditional dc-dc converter such as electrical isolation, high reliability and bidirectional energy flow. Some converters are only suitable for stepping up or stepping down the voltage. This bidirectional converter is used for both stepping up and stepping down the voltage. Therefore charging and discharging should be combined in one circuit topology. For application where the output needs to be completely isolated from the input, isolated converters are employed. For high power applications, full bridge topology is used.

The major concerns of an isolated bidirectional full bridge DC-DC converter with a flyback snubber include reducing switching loss, reducing voltage and current stresses, and reducing conduction loss due to circulation current. The full-bridge type topology has the following merits compared to the single-stage buck-boost type topology:

- Electrical isolation between input and output is guaranteed.
- Higher boost ratio can be implemented.
- System protection is possible when output stage short take place.

For these reasons a full bridge type topology has been chosen for the bi-directional DC-DC converter. The objective of the thesis is to introduce a fly back snubber to recycle the absorbed energy in the clamping capacitor. The fly back snubber can be operated independently to regulate the voltage of the clamping capacitor; therefore, it can clamp the voltage to a desired level. During start-up, the fly back snubber can be controlled to precharge the high-side capacitor, improving feasibility significantly. The use of a bi-directional DC-DC converter with a flyback snubber fed dc motor drive devoted to electric vehicles (EVs) application allows a suitable control of both motoring and regenerative braking operations.

The objective of the paper is to compare bidirectional DC-DC converter with RCD, active clamp and flyback snubber. From the comparison, to prove that flyback snubber in the bidirectional converter is better to reduce the current stress and voltage spikes of the active switches. The Section I give the Introduction of the bidirectional converter for hybrid electric vehicle. Section II is helpful to understand the background of related work. Section III explains the simulations and its results and the last section IV concludes the paper and followed by the references.

II. CIRCUIT DESCRIPTION

The proposed isolated bidirectional full-bridge DC-DC converter with a flyback snubber is shown in Fig. 1. The converter is operated with two modes which are buck mode and boost mode. Fig.1 consists of a current-fed switch bridge, a flyback snubber at the low-voltage side, and a voltage-fed bridge at the high-voltage side. Inductor  $L_m$  performs output filtering when power flows from the high-voltage side to the batteries, which is denoted as a buck mode. On the other hand, it works in boost mode when power is transferred from the batteries to the high-voltage side.

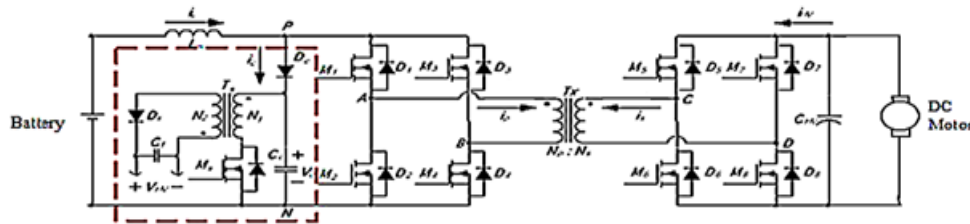

Fig.1 Isolated bidirectional full-bridge DC-DC converter with a flyback snubber [1]

The clamp branch capacitor  $C_c$  and diode  $D_c$  are used to absorb the current difference between current-fed inductor  $L_m$  and leakage inductance  $L_{ll}$  and  $L_{lh}$  of isolation transformer  $T_x$  during switching commutation. The flyback snubber can be independently controlled to regulate  $V_c$  to the desired value, which is just slightly higher than  $V_{AB}$ . Thus, the voltage stress of switches  $M_1$ – $M_4$  can be limited to a low level. A bidirectional DC-DC converter has two types of conversions: step-up conversion (boost mode) and step-down conversion (buck mode). In boost mode, switches  $M_1$ – $M_4$  are controlled, and the body diodes of switches  $M_5$ – $M_8$  are used as a rectifier. In buck mode, switches  $M_5$ – $M_8$  are controlled, and the body diodes of switches  $M_1$ – $M_4$  operate as a rectifier.

A. STEP UP OPERATION

First of all switches  $M_1$ – $M_4$  are turned on, so the primary side of the transformer is short circuited and therefore  $V_{AB}=0$ . Inductor,  $L$  is charged by the battery. At  $t_1$ ,  $M_1$  &  $M_4$  remain conducting, so  $V_{AB}$  is present. Clamping diode,  $D_c$  continues to conduct until the current difference drops to zero at  $t_2$ . Moreover  $D_5$  and  $D_8$  are conducting to transfer the power. During this interval ( $i_L - i_p$ ) flows into clamping capacitor. So clamp capacitor voltage,  $V_c$  is rising at the interval  $t_1$ – $t_2$  and  $i_p = i_L$  condition is reached. During  $t_2$ – $t_3$ ,  $D_c$  stops conduction and flyback snubber starts to operate.  $C_c$  is discharging and the flyback switch is turned on and the energy is stored in flyback snubber as flux. In the interval  $t_3$ – $t_4$  energy stored in the inductor is transferred to high voltage side. Over this interval, flyback snubber will operate independently to regulate  $V_c$  to  $V_{C(R)}$ . Energy stored in the transformer of the flyback snubber is transferred to the output when flyback switch turns off. At  $t_4$ ,  $V_c$  has been regulated to  $V_{C(R)}$  and the snubber remains idle. Over this interval the main power stage is still transferring power from low voltage to high voltage side. It stops at  $t_5$  and completes a half switching cycle operation.

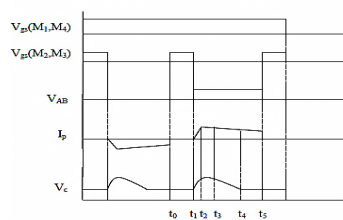

Fig 2 Modes of Operation

B. STEP DOWN OPERATION

During the time period  $t_0$ – $t_1$ , switches  $M_5$  and  $M_8$  are on, while switches  $M_6$  and  $M_7$  are in the off state. High side voltage is immediately exerted on the transformer and the whole voltage is exerted on the transformer causing current to rise. With transformer current,  $i_s$  increasing linearly towards the load current at  $t_1$ , switches,  $M_1$  and  $M_4$  are conducting to transfer the power and the voltage across the transformer terminals on the current fed side changes immediately to reflect the voltage from the voltage fed side.

At  $t_1$ , switch  $M_8$  remain conducting, while switch  $M_5$  is turned off. Diode,  $D_6$  starts to conduct the freewheeling leakage current. Transformer current reaches the load current level at  $t_1$  and starts to decrease during the interval  $t_1$ – $t_2$  and voltage  $V_{AB}$  starts to decrease. The clamping diode,  $D_c$  starts to conduct during this interval.

At  $t_2$ , with diode,  $D_6$  conducting, switch,  $M_6$  can be turned on under ZVS. At  $t_3$ , switch  $M_6$  remains conducting, while switch,  $M_8$  is turned off. Diode,  $D_7$  then starts to conduct the freewheeling leakage current.

At  $t_4$ , with the diode,  $D_7$  conducting, switch  $M_7$  can be turned on under ZVS. Over this interval, the active switches change to the other pair of diagonal switches and the voltage on the transformer reverse its polarity to balance the flux and to alleviate the transient voltage problem. It stops at  $t_5$  and completes a half switching cycle operation.

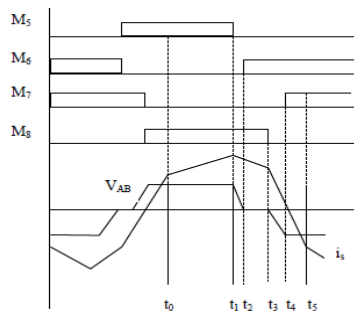

Fig.3 Modes of operation

An isolated bidirectional full bridge DC-DC converter transformer had voltage spikes due to the current difference between the current fed inductor and leakage inductance of the isolation transformer. This voltage spike has been alleviated by the flyback snubber. The flyback snubber can be controlled to attain a soft start-up feature. The current stress is reduced under heavy load conditions. This converter has also the advantage of increased reliability and efficiency.

### III. SIMULATIONS

The simulation of the proposed paper is carried out using MATLAB software. The open and closed loop simulation of buck mode and boost mode is done separately. For open loop simulation, PWM pulses are given as the gating signal. For closed loop simulation, a voltage and current feedback circuit is considered. The isolated bidirectional DC-DC full bridge converter with and without flyback snubber is simulated. The battery fed drive for electric vehicles using isolated bidirectional DC-DC converter with a flyback snubber is also simulated. The simulations are performed with following parameters and the design procedure is explained earlier.

TABLE I - SYSTEM PARAMETERS OF BATTERY FED ELECTRIC VEHICLE

PARAMETERS	VALUES
Input voltage	$V_i = 48V$
Output voltage	$V_o = 360V$
Transformer turns ratio	$N_p: N_s = 1 : 0.133$
Duty cycle	$D = 0.8$
Switching frequency	$F_s = 25kHz$
Inductor	$L_m = 500\mu H$
Clamping capacitor	$C_c = 1\mu F$
Flyback capacitor	$C_f = 100\mu F$

#### A. SIMULATION RESULTS OF BOOST OPERATION

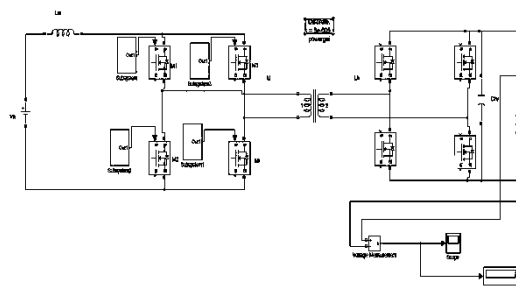

Fig. 5 Simulation circuit of open loop bidirectional full bridge DC-DC converter without flyback snubber- Boost operation

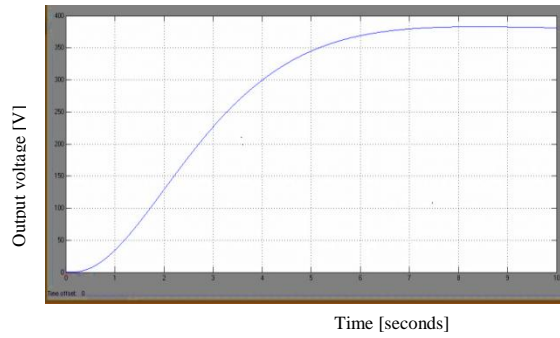

Fig.6 Simulation 1 ' open loop bidirectional full bridge DC-DC converter without flyback snubber- Boost operation

We obtain an output voltage of 381.2V for open loop bidirectional full bridge DC-DC converter without flyback snubber.

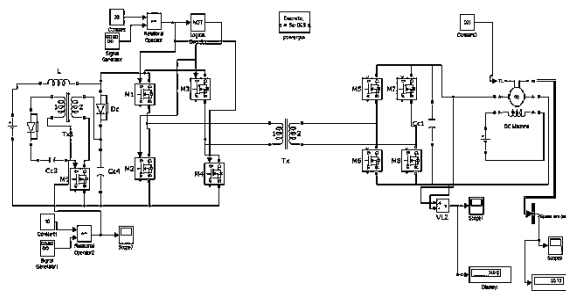

Fig.7 Simulation circuit of bidirectional full bridge DC-DC converter with flyback snubber with DC Motor - Boost open loop operation

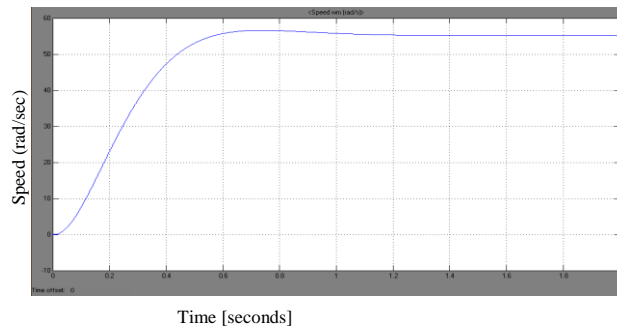

Fig.8 Simulation result of bidirectional full bridge DC-DC converter with flyback snubber with DC Motor - Boost open loop operation (Speed curve)

We obtain a speed of 58.1rad/sec for of bidirectional full bridge DC-DC converter with flyback snubber- Boost open loop operation.

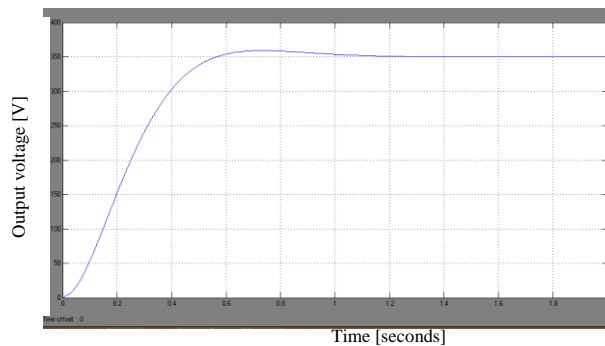

Fig.9 Simulation result of bidirectional full bridge DC-DC converter with flyback snubber with DC Motor - Boost open loop operation with output voltage 350V.

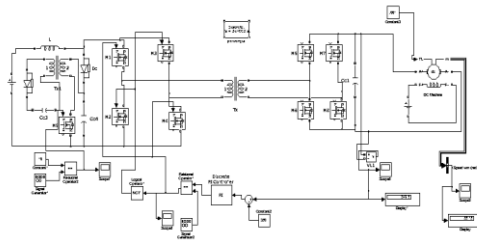

Fig.10 Simulation circuit of bidirectional full bridge DC-DC converter with flyback snubber with DC Motor – Boost closed loop operation

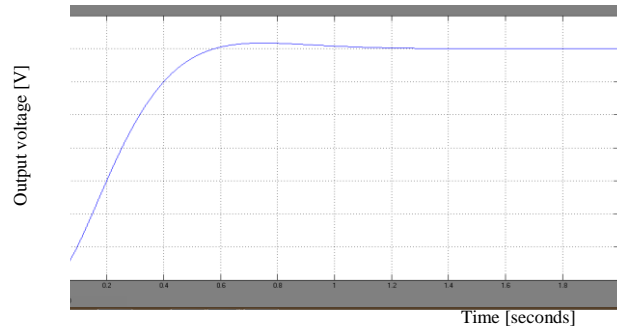

Fig.11 Simulation result of bidirectional full bridge DC-DC converter with flyback snubber with DC Motor – Boost closed loop operation with an output voltage of 350.6V

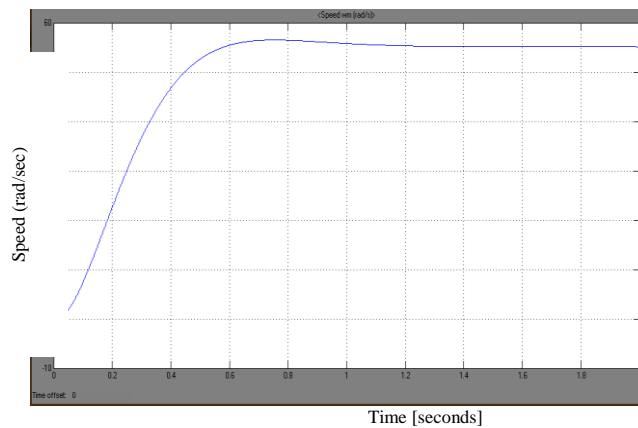

Fig.12 Simulation result of bidirectional full bridge DC-DC converter with flyback snubber with DC Motor – Boost closed loop operation [Speed curve] with a speed of 58.1rad/sec

**B.SIMULATION RESULTS OF BUCK OPERATION**

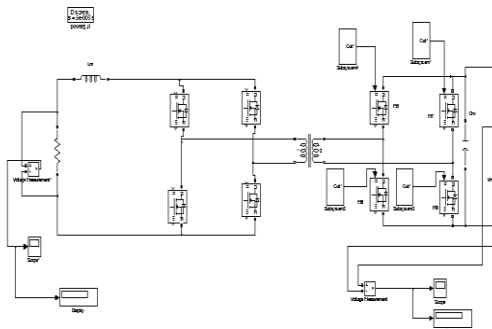

Fig.13 Simulation circuit of open loop bidirectional full bridge DC-DC converter without flyback snubber- Buck operation

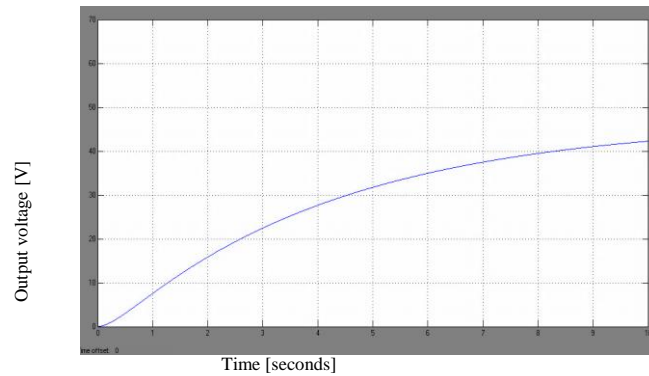

Fig.14 Simulation result of open loop bidirectional full bridge DC-DC converter without flyback snubber- Buck operation

We obtain an output voltage of 42.86V for open loop bidirectional full bridge DC-DC converter without flyback snubber- Buck operation

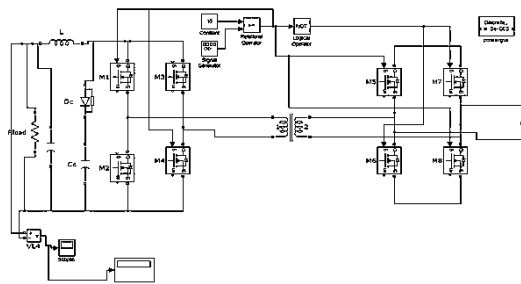

Fig.15 Simulation circuit of bidirectional full bridge DC-DC converter with flyback snubber with DC motor- Buck open loop operation

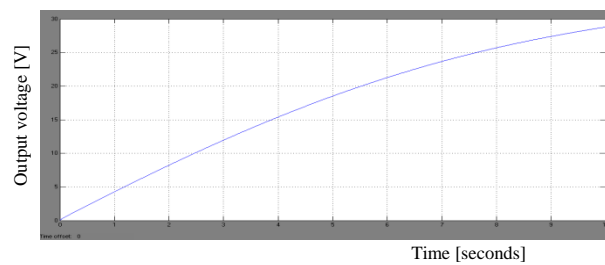

Fig.16 Simulation result of bidirectional full bridge DC-DC converter with flyback snubber with DC Motor - Buck open loop operation with an output voltage of 28.4V.

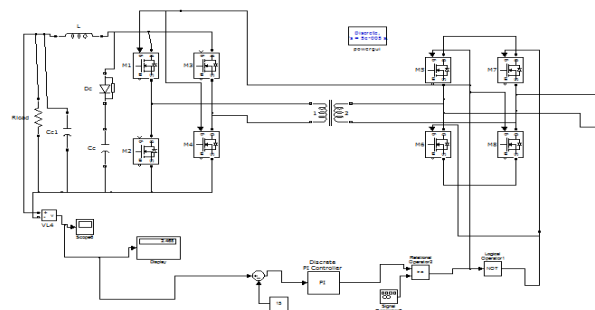

Fig.17 Simulation circuit of bidirectional full bridge DC-DC converter with flyback snubber with DC Motor – Buck closed loop operation

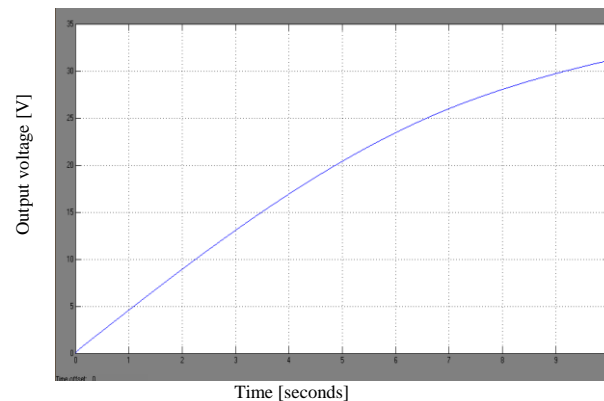

Fig.18 Simulation result of bidirectional full bridge DC-DC converter with flyback snubber with DC Motor – Buck closed loop operation with an output voltage of 32.5V

The simulation results of open loop and closed loop control of isolated bidirectional DC-DC converter with and without flyback snubber for various loads are done. DC motor as a load is used for the simulation in hybrid vehicle application.

#### IV. CONCLUSION

Bidirectional dc-dc converters (BDC) have recently received a lot of attention due to the increasing need of systems with the capability of bidirectional energy transfer between two dc buses. Apart from traditional application in dc motor drives, new applications of BDC include energy storage in renewable energy systems, fuel cell energy systems, hybrid electric vehicles (HEV) and uninterruptible power supplies (UPS).

An isolated bidirectional dc-dc converter with a flyback snubber is presented. The flyback snubber can alleviate the voltage spike caused by the current difference between the current fed inductor and leakage inductance of the isolation transformer, and can reduce the current flowing through the active switches. Since the current does not circulate through the full bridge switches, their current stress can be reduced dramatically. The work demonstrates the performance of a battery operated electric vehicle system and it shows satisfactory performance at different driving condition. The proposed control technique with PI controller find suitable for this electric drive.

#### ACKNOWLEDGMENT

The authors acknowledge gratefully for the support of Electrical and Electronics Department of AmalJyothi college of Engineering, Kanjirappilly and the Electrical and Electronics Department of M A College of Engineering, Kothamangalam

#### REFERENCES

- [1] T. Wu., Y. Chu Chen, J. Yang, and C. Kuo, "Isolated Bidirectional Full-Bridge DC-DC Converter With a Flyback Snubber", IEEE Transactions Power Electronics, Vol.23, pp 1915-1922, 2010.
- [2] X. D. Xue, K. W. E. Cheng, and N. C. Cheung, "Selection of Electric Motor Drives for Electric Vehicles" Australasian Universities Power Engineering Conference (AUPEC'08), Vol.56, pp198-208, 2008.
- [3] K. Wang, F.C. Lee, and J. Lai "Operation principles of bi-directional full-bridge DC-DC converter with unified soft-switching scheme and soft-starting capability" International Journal of Engineering Science and Technology (IJEST), Vol. 3, pp 167-174, 2011.
- [4] M. Rafiq, M. F. Hasan "Design and Analysis of 60 kW DC-DC Converter for Hybrid Electric Vehicle Applications"., IEEE Transactions Power Electronics, vol. 39, pp. 1881-1886, March 2010.
- [4] P.Pany, R.K. Singh, R.K. Tripathi , "Bidirectional DC-DC converter fed drive for electric vehicle system" International Journal of Engineering, Science and Technology, Vol. 3, No. 3, pp. 101-110, 2011.
- [5] O. García, L.A. Flores, J.A. Oliver, J.A Cobos, and J. de la Pena, 'Bi-directional dc-dc converter for hybrid vehicles', IEEE Transactions Power Electronics, vol. 27, no. 3, pp. 1881-1886, 2005.
- [6] T. Bhattacharya, V. S. Giri, K. Mathew, and L. Umanand, "Multiphase Bidirectional Flyback Converter Topology for Hybrid Electric Vehicles", IEEE Transactions Industrial Electronics, vol. 56, no. 1, pp. 78-84, 2009.
- [7] O. C. Onar and A. Khaligh, "A Novel Integrated Magnetic Structure Based DC/DC converter for Hybrid Battery/Ultracapacitor Energy Storage Systems", IEEE Transactions on SMART GRID, vol. 3, no. 1, pp. 296-307, 2012.

### Biography



Divya K. Nair<sup>1</sup> is a PG scholar doing her M. Tech in Power Electronics and Power Systems in AmalJyothi College of Engineering, Kanjirappally. Earlier she has completed her undergraduate in the field of Electrical and Electronics Engineering in Mar Athanasius College of Engineering, Kothamagal.



Elizabeth Rajan<sup>2</sup> has completed her B. Tech in Electrical and Electronics Engineering from St. Joseph College of Engineering, Pala and M. Tech in Power Electronics and Drives from Karunya University, Coimbatore. She currently holds the post of Assistant Professor in the Department of Electrical and Electronics, AmalJyothi college of Engineering, Kanjirappally, Kerala.



K. Radhakrishnan<sup>3</sup> currently holds the post of Professor in the Department of Electrical and Electronics, M A College of Engineering, Kothamangalam.