

# International Journal of Innovative Research in Science, Engineering and Technology

(An ISO 3297: 2007 Certified Organization)

Vol. 3, Issue 6, June 2014

## Failure Analysis of Bearing Cup

Sachin Shelke<sup>1</sup>, Pradnya Kosbe<sup>2</sup>

P.G. Student, Department of Mechanical Engineering, JSPM College, Pune, Maharashtra, India<sup>1</sup>

Associate Professor, Department of Mechanical Engineering, JSPM College, Pune, Maharashtra, India<sup>2</sup>

**ABSTRACT:** Power transmission system has different constructive features according to the vehicle's driving type which can be front wheel drive, rear wheel drive or four wheel drive. In rear wheel drive system, elements of the system include clutch, transmission system, propeller shaft, joints, differential, drive shafts and wheels. Each element has many different designs and construction properties depending on the brands of vehicles. The carden shaft also called drive shaft is used to transmit motion from gear box to differential. The problem identified after critical analysis of the drive shaft assembly. In that bearing cup assembly was getting cracked during assembly operation in universal joint assembly. This was highest rejection, hence it was decided to eliminate bearing cup failure in drive shaft assembly with cost effective solution.

This paper will highlight the methodology adopted for finalizing the solution to this problem by means of the FEA analysis supported by logical reasoning. Various Heat Treatment processes are compared and it was found that Carbonitriding process is the optimum solution which will reduce the failure of bearing cup as well as reduce the overall manufacturing cost.

**KEYWORDS:** Drive shaft, Carden shaft, Heat treatment, carbonitriding, FEA.

### I. INTRODUCTION

The automobile is a typical industrial product that involves a variety of materials and technologies. The present societal needs necessitate that metallic materials are ideally suited for applications in heavily stressed components that require high durability. The degree of functionality and component performance is strongly tied to the effectiveness of the processing technology deployed for a given application.

A propeller shaft or cardan shaft is a mechanical component for transmitting torque and rotation usually used to connect other components of a drive train that cannot be connected directly because of distance or the need to allow for relative movement between them. The universal joint is used to transfer drive (power) from one shaft to another when they are inclined (non collinear) to each other.

### ELEMENTS OF POWER TRANSMISSION SYSTEM

The movement of vehicles can be provided by transferring the torque produced by engines to wheels after some modification. The transfer and modification system of vehicles is called as power transmission system and has different constructive features according to the vehicle's driving type which can be front wheel drive, rear wheel drive or four wheel drive. Fig. 1.3 gives elements of a front wheel and a rear wheel drive power transmission system. The elements of the system include clutch, transmission system, propeller shaft, joints, differential, drive shafts and wheels. Each element has many different designs and construction properties depending on the brands of vehicles. The carden shaft also called drive shaft is used to transmit motion from gear box to differential. The universal joint consists of two forged-steel yokes or forks joined to the two shafts being coupled and situated at an angle to each other. Friction due to rubbing between the journal and the yoke bores is minimized by incorporating needle-roller bearings between the hardened journals and hardened bearing caps pressed into the yoke bores.

### II. LITERATURE SURVEY

Bayrakceken et.al. [2006] did failure analysis of an automobile differential pinion shaft which reveals that the fracture has taken place at a region having a high stress concentration by a fatigue procedure under a combined bending, torsion and axial stresses having highly reversible nature. The crack of the fracture is initiated probably at a material defect

# International Journal of Innovative Research in Science, Engineering and Technology

(An ISO 3297: 2007 Certified Organization)

Vol. 3, Issue 6, June 2014

region at the critical location. Makevet et.al.[2006] in their paper present a case study in failure analysis of a final drive transmission in an off-road vehicle. The failure involved a satellite gear mounting shaft that departed from the differential assembly as a result of fracturing of a retaining pin. An investigation of the mechanical condition of various transmission components, consisting primarily of visual (macroscopic) inspection, geometrical investigation and analysis of mechanical loads, led to the assignment of two principal causes of failure. Firstly, it was established that the retaining pins installed in the assembly were shorter than required, allowing them to shift in their guide holes and assume a single-shear position. Secondly, in this position they were loaded to failure in shear by abnormally high frictional forces acting at the shaft/satellite interface. These loads were attributed to severe usage and handling of the vehicle. Asi [2006] studied the failure analysis of a rear axle shaft used in an automobile which had been involved in an accident. The axle shaft was found to break into two pieces. The investigation was carried out in order to establish whether the failure was the cause or a consequence of the accident. An evaluation of the failed axle shaft was undertaken to assess its integrity that included a visual examination, photo documentation, chemical analysis, micro-hardness measurement, tensile testing, and metallographic examination. The failure zones were examined with the help of a scanning electron microscope equipped with EDX facility. Results indicate that the axle shaft fractured in reversed bending fatigue as a result of improper welding. Substituting composite structures for conventional metallic structures has many advantages because of higher specific stiffness and higher specific strength of composite materials. In their work Lee et al.[2004] one-piece automotive hybrid aluminum/composite drive shaft was developed with a new manufacturing method, in which a carbon fiber epoxy composite layer was co-cured on the inner surface of an aluminum tube rather than wrapping on the outer surface to prevent the composite layer from being damaged by external impact and absorption of moisture. The optimal stacking sequence of the composite layer was determined considering the thermal residual stresses of interface between the aluminum tube and the composite layer calculated by finite element analysis. Press fitting method for the joining of the aluminum/composite tube and steel yokes was devised to improve reliability and to reduce manufacturing cost, compared to other joining methods such as adhesively bonded, bolted or riveted and welded joints. Protrusion shapes on the inner surface of steel yoke were created to increase the torque capability of the press fitted joint. From experimental results, it was found that the developed one-piece automotive hybrid aluminum/composite drive shaft had 75% mass reduction, 160% increase in torque capability compared with a conventional two-piece steel drive shaft. It also had 9390 rpm of natural frequency which was higher than the design specification of 9200 rpm. In his study Mutasher et.al.[2009] studied a hybrid aluminum/composite is an advanced composite material that consists of aluminum tube wound onto layers of composite material. The result from this combination is a hybrid shaft that has a higher torque transmission capability, a higher fundamental natural bending frequency and less noise and vibration. This paper investigates the maximum torsion capacity of the hybrid aluminum/composite shaft for different winding angle, number of layers and stacking sequences. The hybrid shaft consists of aluminum tube wound outside by E-glass and 22 carbon fibers/epoxy composite. The finite element method has been used to analyze the hybrid shaft under static torsion. ANSYS finite element software was used to perform the numerical analysis for the hybrid shaft. Full scale hybrid specimen was analyzed. Elasto-plastic properties were used for aluminum tube and linear elastic for composite materials. The results show that the static torque capacity is significantly affected by changing the winding angle, stacking sequences and number of layers. The maximum static torsion capacity of aluminum tube wound outside by six layers of carbon fiber/epoxy composite at winding angle of 45° was 295 N m. Good agreement was obtained between the finite element predictions and experimental results.

### III. TYPES OF PROPELLER SHAFT

There are different types of propeller shaft or driveshaft in automotive industry

#### 1. Inboard

- i) Single piece shaft
- ii) Two piece shaft

#### 2. Outboard

- i) Single piece shaft
- ii) Two piece shaft.

The slip in tube driveshaft is the new type which also helps in crash energy management. It can be compressed in case of crash. It is also known as a collapsible driveshaft.

# International Journal of Innovative Research in Science, Engineering and Technology

(An ISO 3297: 2007 Certified Organization)

Vol. 3, Issue 6, June 2014

## OBJECTIVE

The main objective of this paper is to solve the problem of bearing cup failure in drive shaft assembly in universal joint assembly during assembly of bearing cup in universal joint which needs to be eliminated with cost effective solution. For that above described heat treatment processes are analysed and compared with each other.

## IV. METHODOLOGY FOR ANALYSIS

As this problem is chronic concerns and high severity concern, systematic concern resolution process is adopted to analyse the problem and find out cost effective solution.

- Step 1: Study all the Heat treatment processes
- Step 2: Study the effect of Surface treatment methods
- Step 3: analyse each method
- Step 4: compare the results of each method
- Step 5: selection best possible solution

## HEAT TREATMENT

Selection of steel types and grades and appropriate heat treatment methods are very important to produce components of reliable quality. The control of a given alloy's chemical composition and the inclusion content of steel have an impact upon and can create variance in an alloy's properties. Other contributing factors impacting the quality and reliability of final components include refining, casting, rolling and cooling methods. Further strength, toughness, fatigue strength and wear properties result largely from the microstructure and hardness results created by heat-treatment condition and methods applied. As a result it is quite important to be cognizant of these factors and to ensure that appropriate methods are applied.

### Carburizing

Carburizing is a case-hardening process in which carbon is dissolved in the surface layers of a low-carbon steel part at a temperature sufficient to render the steel austenitic structure, followed by quenching and tempering to form a martensitic microstructure. The resulting gradient in carbon content below the surface of the part causes a gradient in hardness, producing a strong wear-resistant surface layer on a material, usually low-carbon steel, which is readily fabricated into parts. In gas carburizing commercially the most important variant of carburizing the source of carbon is a carbon-rich furnace atmosphere produced either from gaseous hydrocarbons, for example, methane ( $\text{CH}_4$ ), propane ( $\text{C}_3\text{H}_8$ ), and butane ( $\text{C}_4\text{H}_{10}$ ), or from vaporized hydro-carbon liquids.

Carburizing is a remarkable method of enhancing the surface properties of shafts, gears, bearings, and other highly stressed machine parts. Low-carbon steel bars are fabricated by forging and machining into finished shapes and then are converted by carburizing into a composite material consisting of a high-carbon steel case and low-carbon steel core. When this steel composite is quenched to martensite and tempered, the high hardness and strength of the case microstructure, combined with the favourable case compressive residual stress developed by interactions between the case and core during quenching produce very high resistance to wear, bending fatigue and rolling-contact fatigue.

At first glance, the microstructures of carburized steels appear to be quite straightforward. High-carbon martensite is gradually replaced by martensite of lower carbon content with increasing distance from the carburized surface. This view of the microstructures of carburized steel is essentially correct. Lightly tempered martensite is the dominant micro structural constituent of properly carburized steel. However the martensite changes in morphology, amount and properties as a function of distance from the surface. Other micro structural constituents may also be present and may significantly affect the performance of carburized parts. These other micro structural components include retained austenite, carbides of various origins, sizes and morphologies, inclusions, processing-induced surface oxides, prior austenite grain boundaries embrittled by phosphorus segregation; and nonmartensitic transformation products of austenite, such as bainite and pearlite.

### Carbonitriding

Carbonitriding is a modified form of gas carburizing, rather than a form of nitriding. The modification consists of introducing ammonia into the gas carburizing atmosphere to add nitrogen to the carburized case as it is being produced.

# International Journal of Innovative Research in Science, Engineering and Technology

(An ISO 3297: 2007 Certified Organization)

Vol. 3, Issue 6, June 2014

Nascent nitrogen forms at the work surface by the dissociation of ammonia in the furnace atmosphere; the nitrogen diffuses into the steel simultaneously with carbon. Typically, carbonitriding is carried out at a lower temperature and for a shorter time than is gas carburizing, producing a shallower case than is usual in production carburizing. In its effects on steel, carbonitriding is similar to liquid cyaniding. Because of problems in disposing of cyanide-bearing wastes, carbonitriding is often preferred over liquid cyaniding. In terms of case characteristics, carbonitriding differs from carburizing and nitriding in that carburized cases normally do not contain nitrogen, and nitrided cases contain nitrogen primarily, whereas carbonitrided cases contain both. Carbonitriding is used primarily to impart a hard, wear-resistant case, generally from 0.075 to 0.75 mm (0.003 to 0.030in.) deep. A carbonitrided case has better hardenability than a carburized case (nitrogen increases the hardenability of steel; it is also an austenite stabilizer, and high nitrogen levels can result in retained austenite, particularly in alloy steels). Consequently, by carbonitriding and quenching, a hardened case can be produced at less expense within the case-depth range indicated, using either carbon or low-alloy steel. Full hardness with less distortion can be achieved with oil quenching, or, in some instances, even gas quenching, employing a protective atmosphere as the quenching medium.

## **Nitriding**

Gas nitriding is a case-hardening process whereby nitrogen is introduced into the surface of a solid ferrous alloy by holding the metal at a suitable temperature (below  $A_{c1}$ , for ferritic steels) in contact with a nitrogenous gas, usually ammonia. Quenching is not required for the production of a hard case. The nitriding temperature for all steels is between 495 and 565 °C (925 and 1050 °F). The term liquid nitriding has become a generic term for a number of different fused-salt processes, all of which are performed at subcritical temperature. Operating at these temperatures, the treatments are based on chemical diffusion and influence metallurgical structures primarily through absorption and reaction of nitrogen rather than through the minor amount of carbon that is assimilated. A typical commercial bath for liquid nitriding is composed of a mixture of sodium and potassium salts. The sodium salts, which comprise 60 to 70% (by weight) of the total mixture, consist of 96.5% NaCN, 2.5%  $Na_2CO_3$ , and 0.5% NaCNO. The potassium salts, 30 to 40% (by weight) of the mixture, consist of 96% KCN, 0.6%  $K_2CO_3$ , 0.75% KCNO, and 0.5% KCl. The operating temperature of this salt bath is 565 °C (1050 °F). With aging the cyanide content of the bath decreases and the cyanate and carbonate contents increase (the cyanate content in all nitriding baths is responsible for the nitriding action, and the ratio of cyanide to cyanate is critical). This bath is widely used for nitriding tool steels, including high-speed steels, and a variety of low alloy steels, including the aluminium-containing nitriding steels.

## **Effect of Different Surface Treatment Methods on the Friction and Wear Behaviour.**

After review of several research papers related to wear, following important information related to selected problem was gathered which could lead to decide the methodology and solution. Carburized samples demonstrated the lowest weight losses as compared to quenched and boronized sample when tested for wear for AISI 4140 steel [8]. Samples having greater case depth and surface hardness are more wear resistant than that with low case depth and low surface hardness [9]. Induction hardening improves wear resistance of steel [10][26]. Nitriding improves wear and friction properties of steel [11]. Fatigue and wear of case hardened steel is maximum when the concentration of carbon in the surface layer is 1-1.2% [24].

## **Effect of Different Surface Treatments on Fatigue:**

After reviewing research papers following important information was collected which will be useful for problem resolution.

Nitriding improves fatigue resistance of steel [12][29]. Carburised samples improve fatigue limit of steel [14][22]. Carbonitriding improves fatigue limit of steel [19] [20]. Microstructure plays important role in promoting fracture and fatigue [21]. Fatigue performance of the high temperature gas carburized specimens was relatively poor compared to the conventionally gas carburized specimens [25]. Surface hardness treatment improves fatigue resistance of steel [27].

After all this literature review we conclude that in most of cases in drive shaft failure stress concentration and improper heat treatment were the prime cause for failures. From study related to surface treatment, it is concluded that we will be able to achieve case hardness and hence wear resistance by various processes like induction hardening, carbonitriding, nitriding, nitro carburising which can probably eliminate the through hardening of steel hence we decided to study this process on various parameters and do experimentation to achieve wear resistance and fatigue strengths, Study of different literature reveals that for finding wear behaviour of different material pin on disc or block on disc material

# International Journal of Innovative Research in Science, Engineering and Technology

(An ISO 3297: 2007 Certified Organization)

Vol. 3, Issue 6, June 2014

was used, microstructure and hardness study was also conducted using optical microscope or scanning electron microscope. It is required to adopt similar methods for comparison of different surface treated samples.

## V. FINITE ANALYSIS OF BEARING CUP

### Background:

All the three methods of heat treatment are analysed for better life of the Universal Joint. As discussed above we concluded that major failure in bearing cup is due to the assembly process. During Assembling of the cup in the respective yoke impact load is applied on it. This causes sudden rise in stress level in the cup. This can be analysed by doing some FEA analysis.

The nodes which are constrained are shown in the figure below:

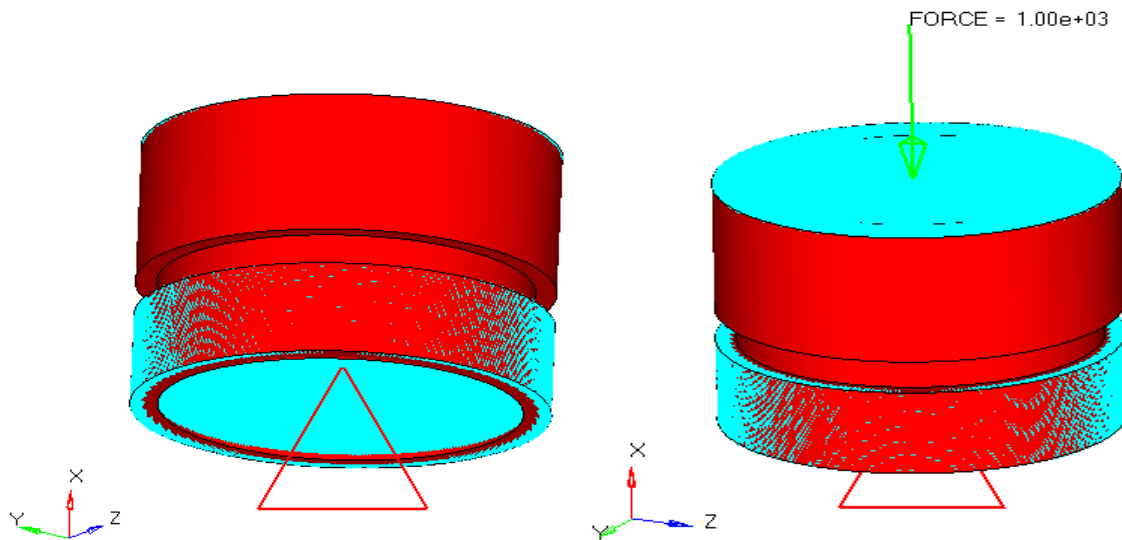

Fig.5: Boundary conditions applied on the bearing cup

Fig.6: Load case

### Loading for Static calculations:

Bearing cup was constraint as per above and impact load of 1000 N was applied on the cup face in vertical direction as shown above.

### Post Processing:

After the solution was achieved the results and the stress plot and deflection plot were viewed and judged for the safety conditions. The results are as follows:

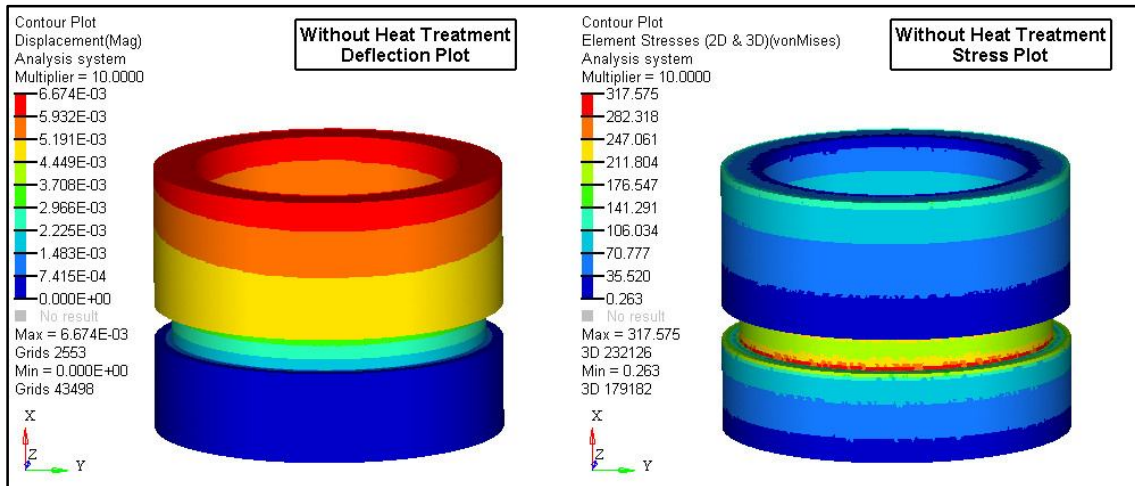

Fig7.: Deflection and Stress Plot (Cup without Heat Treatment)

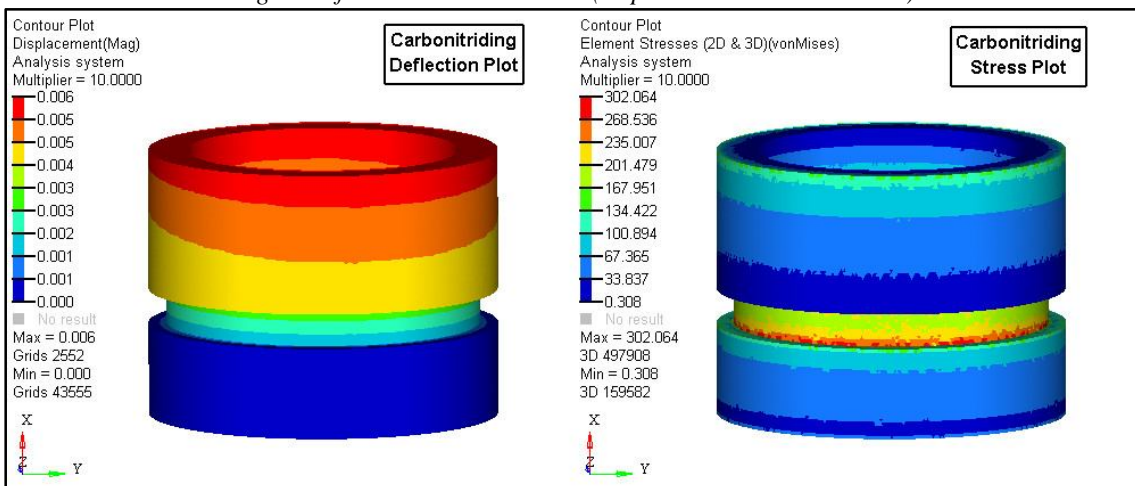

Fig8: Deflection and Stress Plot (Carbonitriding)

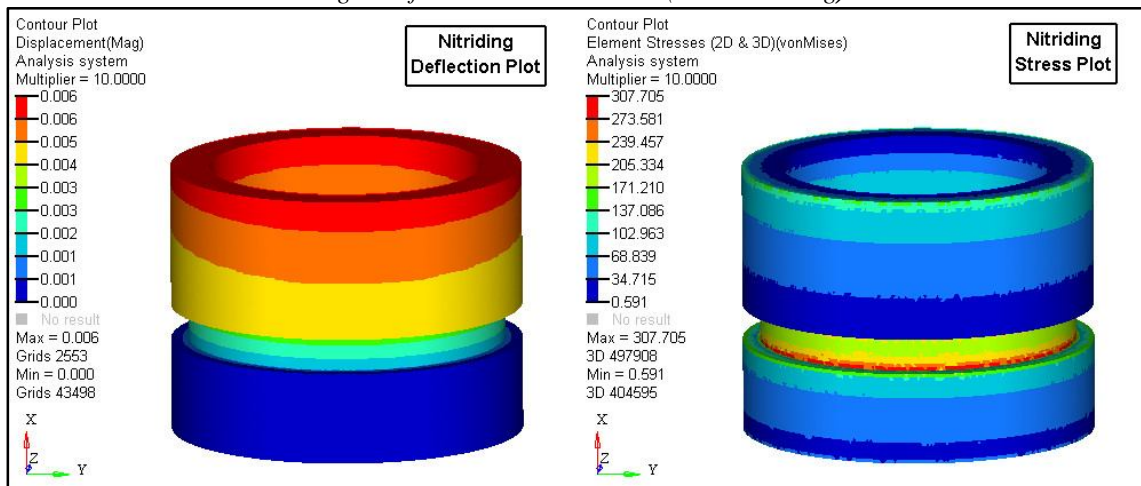

Fig.9:Deflection and Stress Plot (Nitriding)

# International Journal of Innovative Research in Science, Engineering and Technology

(An ISO 3297: 2007 Certified Organization)

Vol. 3, Issue 6, June 2014

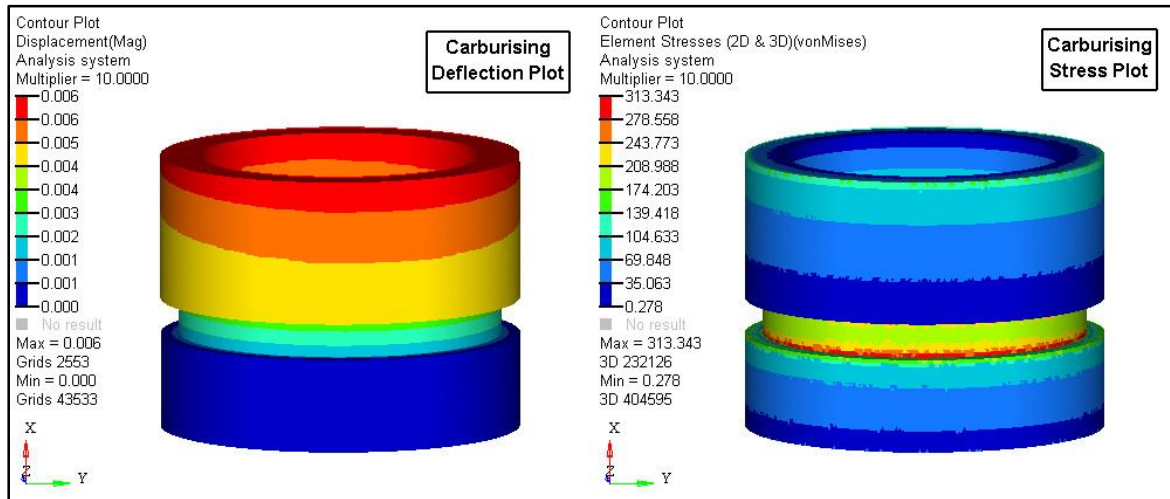

Fig.10: Deflection and Stress Plot (Carburising)

Type of Heat Treatment	Max. Stress at Failure location in MPa
Without any heat treatment	317.575
Carburising	313.343
Nitriding	307.705
<b>Carbonitriding</b>	<b>302.064</b>

Table – 1 Result Comparison

## VI. RESULT ANALYSIS AND CONCLUSION

In this study failure analysis of bearing cup was carried out. Bearing cup assembly was produced from SAE1117 low carbon carburising steel and was surface treated by carburising, hardening and tempering processes. Analysis revealed that bearing cup was failing due to through hardening at groove, as wall thickness was less in this area which results into brittle failure during assembling process. Alternate heat treatment processes like carbonitriding and nitriding were tested in FEA software. From above results following conclusions can be drawn.

1. Carburising and hardening processes achieve good results to achieve martensite structures which gives good wear resistance. Hardness achieved at surface was within range of 58-62 RC. Case depth achieved was high, 0.8 -1.1mm. However this causes through hardening at groove area of bearing cup hence push out force was less in case of carburised and hardened samples as compare to other samples which was average 285Kg. Stress level after Carburising found to be 313.343MPa compared to 317.575MPa (without any heat treatment). This means Carburising can reduce the cup failure.
2. Carbonitriding and hardening processes show good results to achieve a martensite structure which gives good wear resistance. Hardness achieved at surface was within range of 58-62 RC; case depth achieved was less (0.3-.045mm) as compared to that achieved by carburising and hardening (0.8 to 1.1mm). Push outforce was high as compared carburised and hardened samples which was average 885 kg. Stress level after Carbonitriding found to be minimum equal to 302.064MPa compared to 317.575MPa (without any heat treatment). This means Carbonitriding can reduce the cup failure greater than any other heat treatment process.

# International Journal of Innovative Research in Science, Engineering and Technology

(An ISO 3297: 2007 Certified Organization)

Vol. 3, Issue 6, June 2014

3. Nitriding process achieves good surface hardness @ 566 Hv1. However case depth achieved is less than 10 microns. Core hardness was 30 RC. Case microstructure was fine tempered martensite. Push out force for nitrided bearing cup was average 1015Kg. Stress level after Nitriding found to be 307.705MPa compared to 317.575MPa (without any heat treatment). This means Nitriding can also reduce the cup failure but not more than Carbonitriding process.

4. Carbonitriding process as heat treatment process for bearing cup assembly has given good results over earlier process of surface hardening.

## REFERENCES

- [1] M. Godec, DJ. Mandrino, M. Jenko —Investigation of fracture of car's drive shaft Institute of Metals and Technology Ljubljana, Slovenia, Elsevier- Engineering failure analysis, pp 1252-1261, 2009.
- [2] H. Bayrakceken, Failure analysis of automobile differential pinion shaft Elsevier -Engineering failure analysis, pp 1422-1428, 2006
- [3] E. Makevet, I Roman, Failure analysis of final drive transmission in off-road vehicle Elsevier -Engineering failure analysis, pp 579-592, 2002
- [4] Osman Asi, Fatigue failure of rear axle shaft of an automobile Elsevier-Engineering failure analysis, pp 1293-1302, 2006.
- [5] Dai Gil Lee, Hack sung kim, Jong woonkim, Jin kook kim —Design and manufacture of an automotive hybrid aluminium/composite drive shaft Elsevier-Composite structures pp 87-99, 2004.
- [6] S.A. Mutasher, Prediction of torsional strength of the hybrid aluminium/composite drive shaft Elsevier- Materials and Design 2009 pp 215-220.
- [7] Kiyoshi Funatani, Heat treatment of automotive components IMST Institute, Nagoya, Aichi JAPAN Trans Indian Inst. Met. Vol. 57, No.4, pp 381-396, 2004.
- [8] Mustafa Ulutan, Osman N. Celik, Effect of Different Surface Treatment Methods on the Friction and Wear Behaviour of AISI 4140 Steel Elsevier -J. Mater. Sci. Techno., pp 251-257, 2010.
- [9] M. Izciler, Abrasive wear behaviour of different case depth gas carburized AISI 8620 gear steel Elsevier- Wear, PP 90-98, 2006.
- [10] H. Sert, A. Canl, Wear behaviour of different surface treated cam spindles Elsevier- Wear, pp 1013-1019, 2006.
- [11] A. Ben Cheikh Larbi, Improvement of the adhesive wear resistance of steel by nitriding quantified by the energy dissipated in friction Elsevier- Wear, PP 712-718, 2005.
- [12] Mohamed Ali, Fatigue life evaluation of 42CrMo4 nitrided steel by local approach: Equivalent strain-life-time Elsevier- Material and Design 33, PP 444-450, 2012.
- [13] D. Rodziňák, R. Zahradníček, effect of nitridation on contact fatigue and wear damage of Austempered and CrM steels Acta Metallurgica Slovaca, Vol. 16, No. 1, pp. 12-19, 2010.
- [14] George Fillari, Thomas Murphy, Igor Gabrielov, Effect of case carburizing on mechanical properties and fatigue endurance limits of p/m steels.
- [15] K. palaniradja, N. alagumurthi. Optimization of process variables in gas carburizing process Turkish J. Eng. Env. Sci. 29, pp 279-284, 2005.
- [16] C. Kanchanomai and W. Limtrakarn, Effect of residual stress on fatigue failure of carbonitrided low-carbon steel ASM international- journal of materials Engineering and performance volume 17, pp 879-887, 2008.
- [17] J.P. Wise, G. Krauss, Microstructure and fatigue resistance of carburized steels 20th ASM Heat Treating Society Conference Proceedings, 9-12, St. Louis, MO, ASM International, 2000.
- [18] B.A. Shaw, A.M. Korsunsky. Surface treatment and residual stress effects on the fatigue strength of carburized gears.
- [19] A.C. Batista, A.M. Dias, Contact fatigue of carbonitrided gears effect of residual stresses Faculdade de engenharia da universidade do porto June 2003.
- [20] Chikaraooki, Kikuo Maeda. Improving rolling contact fatigue life of bearing steels through grain refinement NTN technical review 2004.
- [21] J. J. Kruzic, J. H. Schneibel, Role of microstructure in promoting fracture and fatigue resistance in Mo-Si-B Alloys Materials Research Society. Vol. Pp 842, 2005.
- [22] George Fillari, Thomas Murphy, Effect of heat treatment and case carburizing high density p/m steels.
- [23] Kyuhong Lee, Duk-hyunnam. Correlation of microstructure with hardness and wear Resistance in (CrB, MoB)/steel surface composites fabricated by high-energy electron beam irradiation metallurgical and materials transactions Volume 37A, pp 663-673, 2006.
- [24] G. D. Fomenko, V. S. Egorov and A. G. Andreeva, Investigation of the wear resistance of case hardened 12KhN3A steel translated from Metallovedenie i Termicheskaya Obrabotka Metallov, No. 1, pp. 23-25, 1963.
- [25] Osman Asi, Ahmet Cetin can. Effect of high temperature gas carburizing on bending fatigue strength of gas carburized SAE 8620 Steel. Surface & coating technology 201, pp 5779-5987, 2007.
- [26] T. Slatter, The influence of induction hardening on the impact wear resistance of compacted graphite iron (CGI) Elsevier- Wear 270, PP 302-311, 2011.
- [27] H. Guechichi, L. Castex Fatigue limits prediction of surface treated materials Elsevier- Journal of material processing technology, PP 381-387, 2006.
- [28] M. Elmadagli, A parametric study of the relationship between microstructure and wear resistance of Al-Si alloys Elsevier- Wear, pp 79-92, 2007.
- [29] Chang-min Suh, Byung-won Hwang, Characteristics of Fatigue crack initiation and fatigue strength of nitrided 1Cr-1Mo-0.25V turbine rotor steel. KSME international journal, Vol 16 no.8, pp 1109-1116, 2002.
- [30] Pin-on-disc Tribometer (TR-20 LE) lab manual, Ducom, Bangalore, India
- [31] ASM handbook of Heat treating - Volume 4.
- [32] Design Manual of Universal joint & drive shaft AE-7.