



# Harmonic Analysis of 1.5 kW Photovoltaic System in the Utility Grid

V.Tamilselvan<sup>1</sup>, V.Karthikeyan<sup>2</sup>

Associate Professor, Dept. of EEE, Adhiyamaan College of Engineering, Hosur, Tamilnadu, India<sup>1,2</sup>

**ABSTRACT:** The photovoltaic systems are safe and clean source of energy, so the use of photovoltaic systems has been rapidly increasing nowadays. The harmonic has to be analyzing for 1.5kW photovoltaic system in the utility grid at the point of common coupling. The grid-connected photovoltaic system is used to provide energy for local loads and for exchanging the power with utility grids. At the point of common coupling, this power quality problem arises mainly due to the connection of non-linear loads and this issue has to be suppressed. This paper assesses the impact of PV generation on the distribution system and important issues such as reverse power flow and harmonic distortion are analyzed.

**KEYWORDS:** Photovoltaic system, harmonic analysis, utility grid.

## I.INTRODUCTION

Photovoltaic source is one of the biggest contributions to electricity generation among all the renewable energy sources, because it is clean, emission-free and high reliability. This energy system has several advantages when compared to other forms of renewable energy. The power generated by the photovoltaic system can be delivered to the power system networks through grid connected inverters. Since the PV module has non-linear characteristics, it is necessary to design the simulation for maximum power point tracking. A solar cell (or photovoltaic cell) converts sunlight (light energy) into electricity (electrical energy). The solar cells are either made up of germanium or silicon. A group of PV cells are connected together in series or parallel configuration to form a PV module. Similarly a group of PV modules are connected together to form a PV array and group of PV arrays form a PV panel.

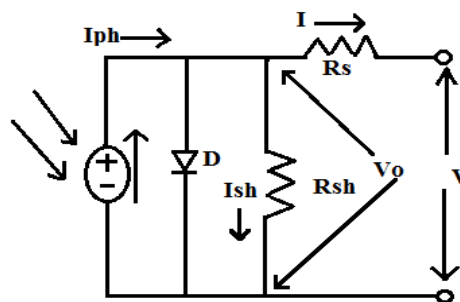

Fig 1: Equivalent electrical circuit of PV cell

The default parameters which were utilized to characterize the PV module in MATLAB are appeared in Table I. The model empowers the client to indicate the quantity of series and parallel cells per module and the quantity of modules associated in series and in parallel which assists in building P-V frameworks with high power rating. Fig. 2 and Fig. 3 after effects of V-I characteristic and P-V characteristic got by the MATALAB demonstrate in Fig.4.



# International Journal of Advanced Research in Electrical, Electronics and Instrumentation Engineering

(An ISO 3297: 2007 Certified Organization)

Vol. 5, Issue 12, December 2016

Table I: Specifications of PV module

Parameters	Value
Open circuit voltage/cell	0.5V
Number of cells/module	10
Number of modules/ panel	12
Total number of cells/ panel	120
Maximum voltage of panel	28.96V
Maximum current of panel	8.28A
Maximum power of panel	240W
Total capacity	1.5KW

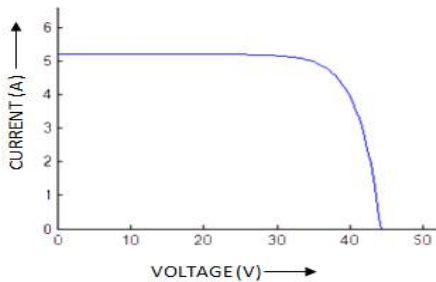

Fig 2: V-I Characteristics of PV cell

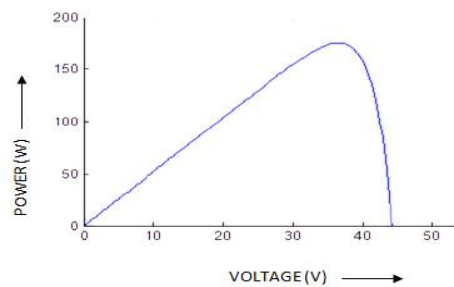

Fig 3: P-V Characteristics of PV cell

## II. BOOST CONVERTER

Switched mode DC-DC converter changes over unregulated DC input voltage into managed DC yield voltage at a predetermined voltage level. Switched power supplies offer significantly more effectiveness and power thickness contrast with straight power supplies. Essential converters that progression up or venture down voltage input contains components like transistors, diodes, capacitor and inductors. Three fundamental converter topologies exist; they are buck (step- down), boost (step- up) and buck-boost (step up or step down). In our proposed configuration boost topology is utilized on the grounds that its freewheeling diode can be utilized for blocking reverse current and it productively intensify PV clusters yield voltage into more elevated amount. Converters are controlled by pulse width modulation (PWM) duty cycle since the yield of converter being dictated by condition of transistor switch. Along these lines ideal load impedance of PV module is accomplished by changing duty cycle.

## III. MODELLING OF MPPT

A typical solar panel converts only 30 to 40 percent of the incident solar irradiation into electrical energy. Maximum power point tracking technique is used to improve the efficiency of the solar panel. The Perturb & Observe algorithm states that when the operating voltage of the PV panel is perturbed by a small increment, if the resulting changes in power  $\Delta P$  is positive, then we are going in the direction of MPP and we keep on perturbing in the same direction. If  $\Delta P$  is negative, we are going away from the direction of MPP and the sign of perturbation supplied has to be changed. Fig. 5 explains the about perturb and observe algorithm for MPPT technique. Fig. 6 shows the MPPT block used in the MATLAB simulation for grid connected PV system.

# International Journal of Advanced Research in Electrical, Electronics and Instrumentation Engineering

(An ISO 3297: 2007 Certified Organization)

Vol. 5, Issue 12, December 2016

## IV.GRID TIE INVERTER

A grid tie inverter is a power inverter that converts direct current (DC) electricity into alternating current (AC) with an ability to synchronize with the utility line. The grid tie inverter must synchronize its frequency with that of the grid (50Hz) and limit the voltage from exceeding the grid voltage. A modern grid tie inverter has a fixed unity power factor. The inverter supplying reactive power to the grid might be necessary to keep the voltage of the grid within allowable limits. Fig. 7 shows the grid tie inverter circuit using MATLAB. The synchronization of the inverter output voltage with the grid must satisfy the following conditions,

1. The voltage of the inverter must be equal to the grid voltage.
2. The phase sequence of the grid voltage and the inverter voltage must be equal.
3. The frequency of the grid and the grid tie inverter must be equal.

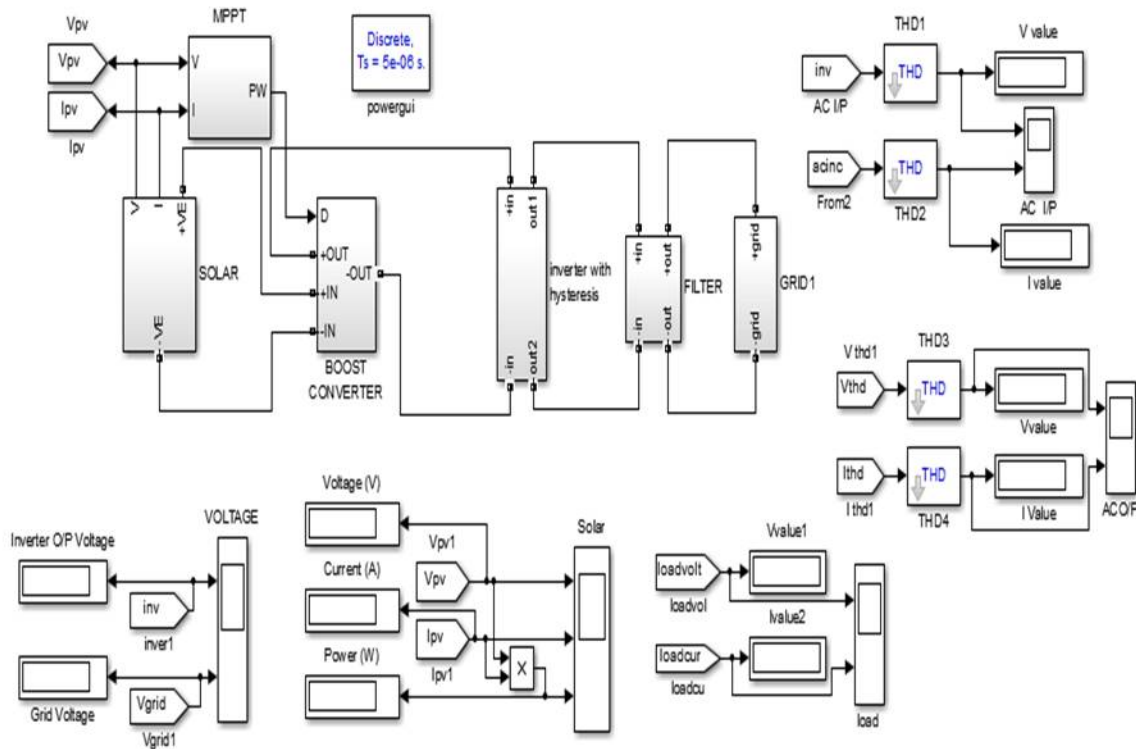

Fig 4: Simulation diagram of grid connected photovoltaic system

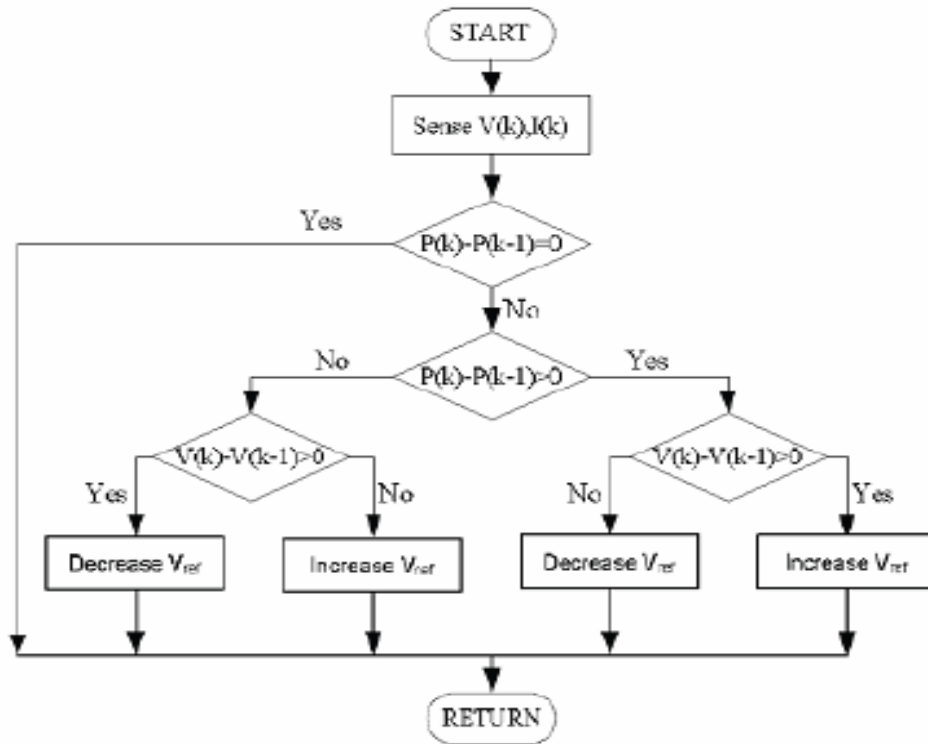

Fig 5: Perturb and Observe Algorithm

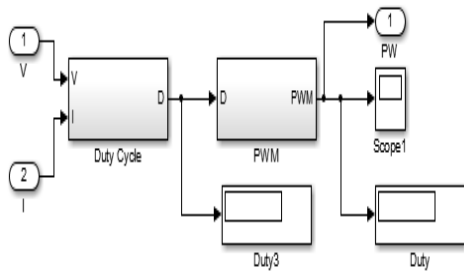

Fig 6: Mppt Block

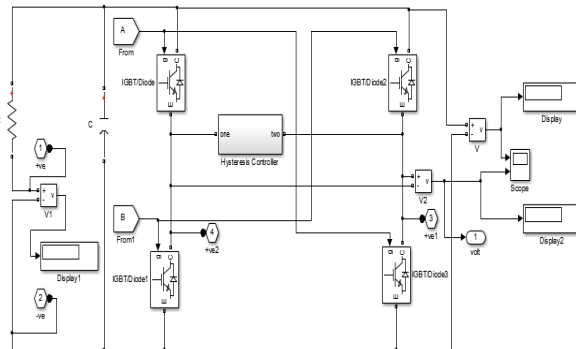

Fig 7: Inverter Circuit

### V. TOTAL HARMONIC DISTORTION

Total harmonic distortion is defined as the ratio of root-mean-square of the harmonic content to the root-mean-square value of the fundamental quantity and expressed as a percent of the fundamental or simply is a measurement of the level of harmonic distortion present in power systems. The Total Harmonic Distortion in terms of % is given as,

$$THD = \sqrt{\frac{\text{sum of squares of amplitude of all harmonics}}{\text{square of amplitude of fundamental}}}$$



# International Journal of Advanced Research in Electrical, Electronics and Instrumentation Engineering

(An ISO 3297: 2007 Certified Organization)

Vol. 5, Issue 12, December 2016

## VI.ELECTRICAL LOAD

Electrical load is an electrical component of a circuit that consumes electric power. The electrical power consumption depends upon the type of the load and the capacity of the load. In the electric power circuit, some of the loads are appliances and lights. Based on the load nature, the electrical load can be classified into linear loads and non-linear loads. The linear load is an electrical load which has the linear relationship between the current and voltage (i.e) it gives a straight line response. The resistive loads, capacitive loads, inductive loads, transformers are some of the examples of linear loads.

The non-linear load does not have the linear relationship between input and output (i.e.) it gives distorted response. The non-linear load is characterized by the switching action and current interruptions. Some of the non-linear loads that can generate the harmonics are motor, diode, compact fluorescent lamp, etc.

## VII.SIMULATION RESULT

The overall proposed system is implemented in MATLAB as shown in Fig 4. It describes about the results relating to linear and nonlinear loads before and after applying reactive power compensation using capacitor banks at the point of common coupling and gives the results about the total harmonic distortion level. The solar panel voltage, current and power is shown in fig.8. The inverter and grid tie voltage is shown in figure 9. The figure 10 displays the current and the voltage waveforms for linear type of loads after applying the reactive power compensation scheme to the PCC. The current is obtaining nearly unity power factor as shown in the figure. The following fig.11, 12, 13 and 14 displays the total harmonic distortion level present in the input and output current and voltage of the grid, after applying the capacitor compensation scheme to the common point of coupling.

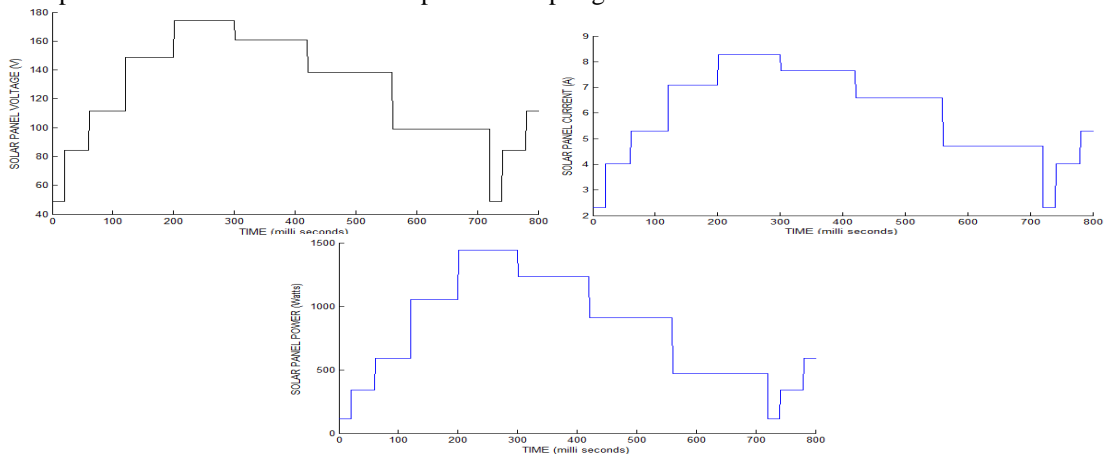

Fig 8: Solar panel voltage, current and power

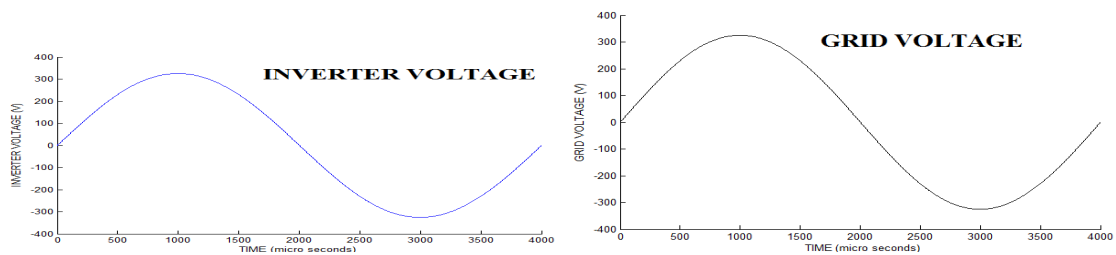

Fig 9: Inverter voltage and grid voltage



# International Journal of Advanced Research in Electrical, Electronics and Instrumentation Engineering

(An ISO 3297: 2007 Certified Organization)

Vol. 5, Issue 12, December 2016

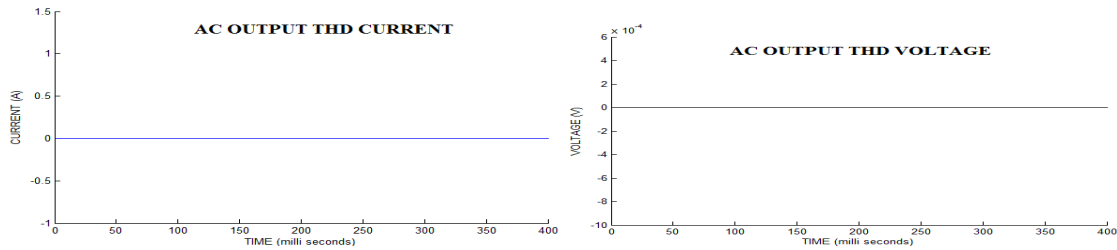

Fig 10: THD for R load

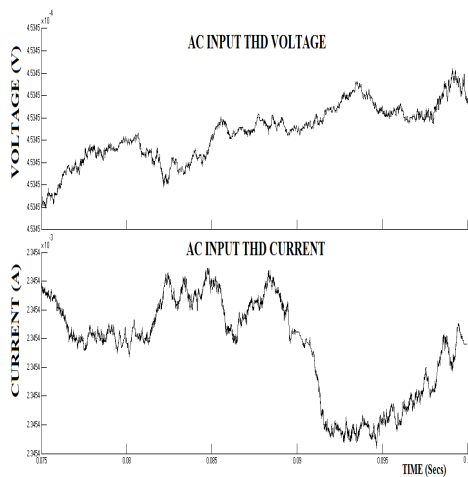

Fig 11: AC input side THD for L load

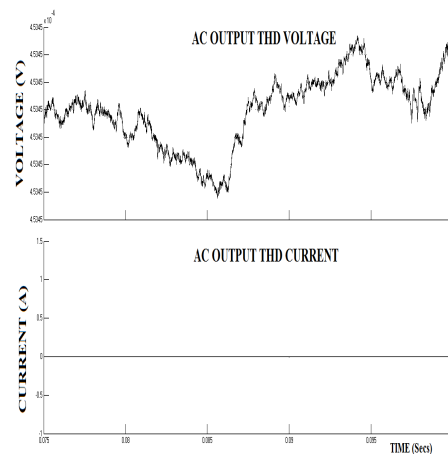

Fig 12: AC output side THD for L load

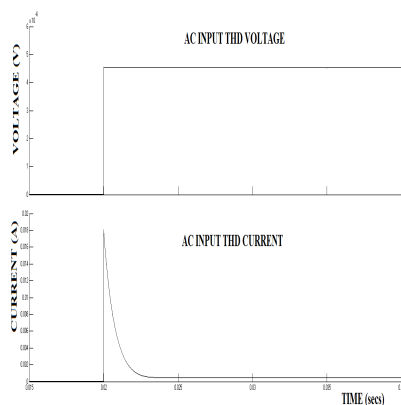

Fig 13: AC input side THD for C load

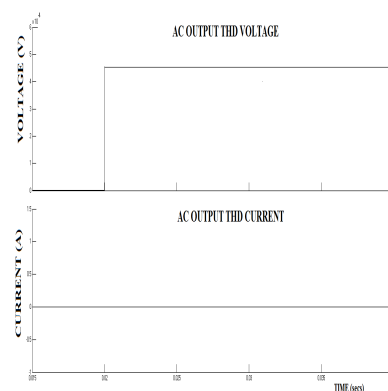

Fig 14: AC output side THD for C load

## VIII.CONCLUSION

The main purpose of this paper is to establish a grid connected photovoltaic system with maximum power point tracking for the residential application. In the proposed design, an MPPT algorithm using a boost converter is designed to operate using P&O method. The photovoltaic system of 1.5kW is synchronizing with the grid at the point of common coupling through the grid tie inverter and the harmonics for the linear and non-linear loads at the point of common coupling is analyze. The grid interfacing inverter can improve the performance of power converter to inject



ISSN (Print) : 2320 – 3765  
ISSN (Online): 2278 – 8875

# International Journal of Advanced Research in Electrical, Electronics and Instrumentation Engineering

*(An ISO 3297: 2007 Certified Organization)*

**Vol. 5, Issue 12, December 2016**

power generated from Renewable energy sources to the grid. The controller controls the real power and reactive power supplied by the distributed generation at the PCC.

## IX.ACKNOWLEDGES

The author gratefully acknowledges the University Grants Commission, New Delhi, for sanctioning and providing financial assistance through minor research project scheme. The author gratefully acknowledge the encouragement and support of Adhiyamaan College of Engineering, Hosur.

## REFERENCES

- [1] Kumar, L. S. C., &Padma, K. Matlab/Simulink Based Modelling and Simulation of Residential Grid Connected Solar Photovoltaic System. In International Journal of Engineering Research and Technology, Vol. 3, No. 3, March-2014. ESRSA Publications.
- [2] Altas, I. H., &Sharaf, A. M. A photovoltaic array simulation model for Matlab-Simulink GUI environment. In 2007 International Conference on Clean Electrical Power, pp. 341-345. IEEE Conference.
- [3] Raut, D. B., &Bhattra, A. Performance Analysis of Grid Connected Solar PV System Using Matlab/Simulink. Rentech Symposium Compendium, Volume 3, September 2013.
- [4] Adhikari, N., Singh, B., &Vyas, A. L. Design and Control of Small Power Standalone Solar PV Energy System. Asian Power Electronics Journal, Vol. 6 No.1, pp. 17-24, Oct. 2013.
- [5] Kjaer, S. B., Pedersen, J. K., &Blaabjerg, F. A review of single-phase grid-connected inverters for photovoltaic modules. IEEE transactions on industry applications, Vol. 41, No.5, pp. 1292-1306, Sep 2005.
- [6] Yao, Z., & Xiao, L. Control of single-phase grid-connected inverters with nonlinear loads. IEEE Transactions on Industrial Electronics, Vol. 60, No.4, pp.1384-1389, April 2013.
- [7] Syam MS, Kailas TS. Grid connected PV system using Cuk converter. In Emerging Research Areas and 2013 International Conference on Microelectronics, Communications and Renewable Energy (AICERA/ICMiCR), 2013 Annual International Conference on June 2013 Vol. 4, pp.1-6. IEEE Conference.