



MODEL BASED CONTROL FOR INTERACTING AND NON-INTERACTING LEVEL PROCESS USING LABVIEW

M.Lavanya¹, P.Aravind², M.Valluvan³, Dr.B.Elizabeth Caroline⁴

PG Scholar[AE], Dept. of ECE, J.J. College of Engineering & Technology, Trichy, Tamilnadu, India¹

PG Scholar[C&I], Dept. of EIE, J.J. College of Engineering & Technology, Trichy, Tamilnadu, India²

Assistant Professor, Dept. of EIE, J.J. College of Engineering & Technology, Trichy, Tamilnadu, India³

Professor, Dept. of ECE, J.J. College of Engineering & Technology, Trichy, Tamilnadu, India⁴

ABSTRACT: Recent advancements in process industries have enabled the development of combination of interacting and non-interacting of process tank level control system. An experimental setup of three tank level process in interacting and non- interacting mode was studied, to obtain the process models. Different control schemes such as Internal model controller (IMC), IMC-PID and Proportional –Integral and Derivative (PID) were implemented. The goal of the model-based controller is to compensate for shifts in the process and maintain the liquid level on target. The performance of different control schemes were investigated through computer simulation.

Keywords: Interacting system, Non-interacting system, IMC, IMC-PID, LabVIEW.

I.INTRODUCTION

Even though control theory has been developed significantly, the proportional- integral-derivative (PID) controllers are used for a wide range of process control, motor drives, magnetic and optic memories, automotive, flight control, instrumentation, etc. In industrial applications, PID type controllers were widely used. With its three-term functionality covering treatment to both transient and steady-state responses, proportional- integral-derivative (PID) control offers the simplest and yet most efficient solution to many real-world control problems. Since the invention of PID control in 1910 (largely owing to Elmer Sperry's ship autopilot), and the Ziegler–Nichols' (Z-N) straightforward tuning methods in 1942 [1], the popularity of PID control has grown tremendously. With advances in technology, the science of automatic control now offers a wide spectrum of choices for control schemes. However, most of industrial controllers were still implementing based around PID algorithms, particularly at lowest levels. This paper presents a [2] case study emphasizes building a mathematical model of a two tank fluid system, followed by system identification and parameter estimation, and finally designing a controller by pole placement. Model based control was developed primarily for processes having a pronounced time delay, the intent being to match the process delay with one in the control system. Model based control is very popular nowadays due to the ability of such controllers to handle process with dead time effectively. Model-based control action is "intelligent" and helps in achieving uniformity, disturbance rejection, and set point tracking, all of which translate into better process economics. One important type of model based control is Internal Model Control [IMC], which has the combined advantage of both open and closed systems[6]. It gives better performance in tracking the set point and load changes[3]. In [4], IMC design concept is extended to multi input-multi output discrete time systems. A good resource for IMC is [5].

An excellent summary on PID tuning methods can be found in [6], [7], and [8]. However, no tuning method so far can replace the simple Z-N method for lower order systems in terms of familiarity and ease of use to start with. This work is based on real time model based control for the level control of a non-interacting and interacting three tank cylindrical tank system found to be second order with delay process. The process model is experimentally determined from step response analysis and it is interfaced to real time with LabVIEW. The controller settings of IMC, IMC PID and the conventional PID controller are analyzed, based on time domain specifications like peak time, overshoot and settling time.



II.SYSTEM IDENTIFICATION

A. Mathematical Modeling

To analyze the behavior of a process, a mathematical representation of the physical and chemical phenomenon taking place in it is essential and this representation constitutes the mathematical model.

B. Experimental Setup

The experimental set up shown in Figure 1 consists of water supply tank, pump, Plunger pump, level transmitter, pressure transmitter, Process tanks, Venturimeter, orifice meters with differential pressure transmitters, rotameter, pneumatic control valve, I/P converter, Pressure gauges. The pneumatic control valve is air to close, adjusts the flow of the water pumped to the cylindrical tank from the water reservoir. The level of the water in the tank is measured by means of the differential pressure transmitter and is transmitted in the form of (4-20) mA to the interfacing ADAM's module to the Personal Computer (PC).

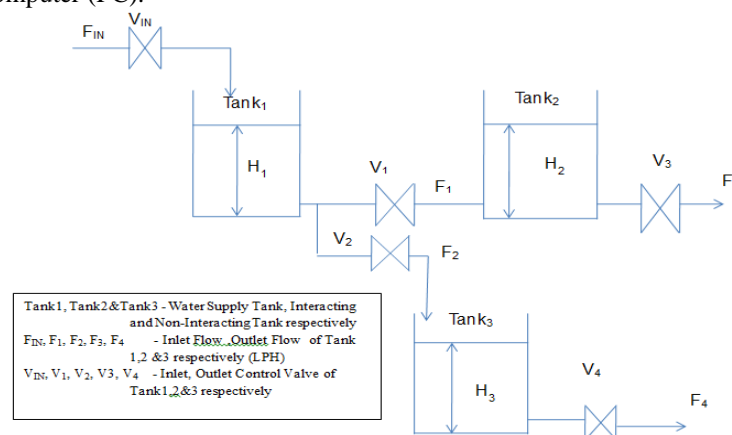

Fig. 1 Experimental Setup of Interacting Non-interacting Tank with Supply Tank

After computing the control algorithm in the PC control signal is transmitted to the I/P converter in the form of current signal (4-20) mA, which passes the air signal to the pneumatic control valve. The pneumatic control valve is actuated by this signal to produce the required flow of water in and out of the tank. There is a continuous flow of water in and out of the tank. The data acquisition system consists of 8 analog inputs and 4 analog outputs and also with 16 digital inputs and 16 outputs. It is voltage based data acquisition card.

Table I Technical Specifications of Experimental Setup

S.NO	COMPONENTS
1	Data Acquisition Interface
2	Communication
3	Process Tank
4	Interacting Tank
5	Supply Tank
6	Level Transmitter
7	I/P Converter
8	Control Valve
9	Pressure Gauge
10	Rotameter
11	Differential Pressure Transmitter



III. INTERNAL MODEL CONTROLLER

A. The Imc Structure

The standard IMC structure is shown in Figure-2, where $G_p(s)$, $G_m(s)$, $G_c(s)$, $d(s)$ denote Process, Model, IMC Controller and Disturbance respectively. The internal model control principle states that control can be achieved only if the control system encapsulates, either implicitly or explicitly, some representation of the process to be controlled. Process model may not be invertible and the system is often affected by unknown disturbances [8]. From the schematic diagram figure 2 $d(s)$ is an unknown disturbance; $U(s)$ is the manipulated input is introduced to both the process and its model [11]. $Y(s)$ is the process output is compared with the output of the model.

The closed loop transfer function for the IMC is,

$$Y(S) = \frac{[R(s)-d(s)]G_c(s)G_p(s)}{1+[G_p(s)-\widehat{G_p}(s)]G_c(s)} + d(s) \quad (1)$$

$$Y(S) = \frac{R(s)G_c(s)G_p(s)+[1-G_c(s)\widehat{G_p}(s)]d(s)}{1+[G_p(s)-\widehat{G_p}(s)]G_c(s)} + d(s) \quad (2)$$

To improve robustness, the effects of process model mismatch should be minimized. This mismatch usually occurs at the high frequency end of the system's frequency response, a low-pass filter $G_f(s)$ is usually added to attenuates the effects of mismatch[3]. The IMC is usually designed as the inverse of the process model in series with a low-pass filter, that is $G_{IMC}(s)=G_c(s)G_f(s)$. The resulting closed loop then becomes.

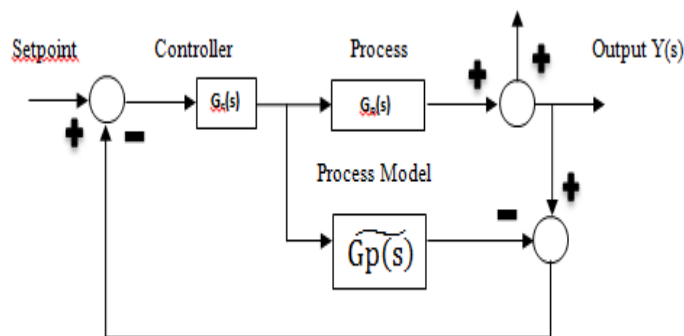

Fig. 2 General Schematic of IMC

$$Y(S) = \frac{G_{imc}(s)G_p(s)R(s)+[1-G_{imc}(s)\widehat{G_p}(s)]d(s)}{1+[G_p(s)-\widehat{G_p}(s)]G_{imc}(s)} \quad (3)$$

IV. THREE TANK SYSTEM

Tank1 is interacting with Tank2 and non-interacting with Tank3 is shown in figure 1.

$$G_o(S) = \frac{R_1 R_2 R_3}{[(A_1 R_1 s + 1)(A_1 R_1 R_2 s + R_2 + R_1) - R_2 (A_3 R_3 s + 1)]} \quad (4)$$

The system identification of real time system can be obtained from the open loop method, for a given change in the input variable. At a fixed inlet flow rate, outlet flow rate, the system is allowed to reach the steady state. After that a step increment in the input flow rate is given, and various readings are noted till the process becomes stable in the tank. The transfer functions of tanks for interacting, non-interacting mode of 3 tank system are given below.

$$G_1(S) = \frac{0.6465}{1+1.1998s} e^{-1.968s} \quad (5)$$

$$G_2(S) = \frac{0.6366}{1+1.2037s} e^{-1.963s} \quad (6)$$

$$G_3(S) = \frac{0.7991}{1+1.8581s} e^{-2.868s} \quad (7)$$



V. RESULT AND DISCUSSION

The three tank level control system is studied under interacting and non-interacting mode. The obtained models were simulated and controller comparison i.e performance analysis of controller was studied from response curves are obtained using LabVIEW [10] Environment.

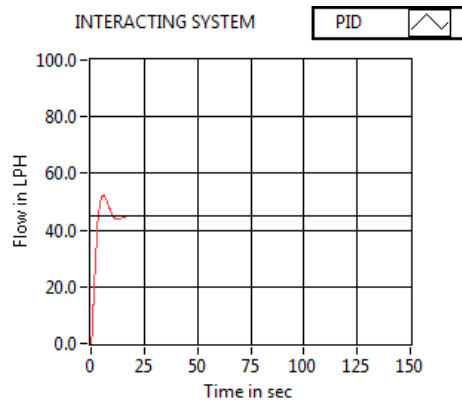

Fig. 3 Response of PID Control Action for Interacting System to Setpoint 45cm

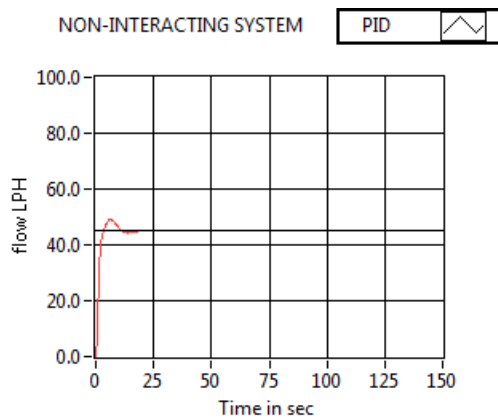

Fig. 4 Response of PID Control Action for Non-Interacting System to Setpoint 45cm

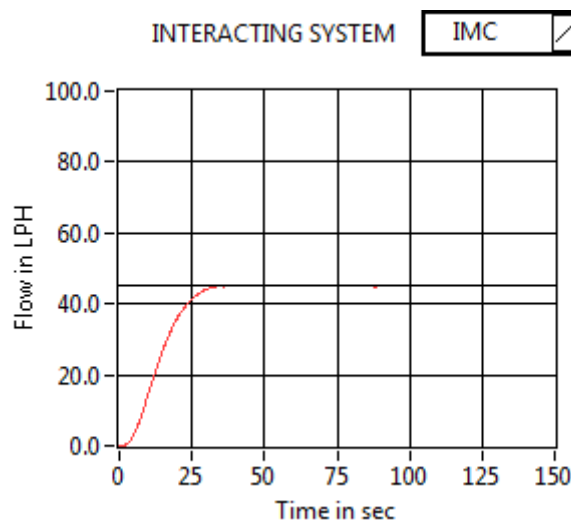

Fig. 5 Response of IMC for Interacting System to Setpoint 45cm

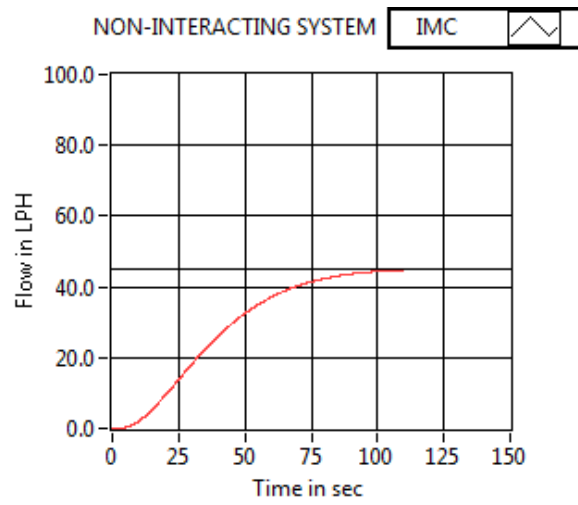

Fig. 6 Response of IMC Control Action for Non-Interacting System to Setpoint 45cm

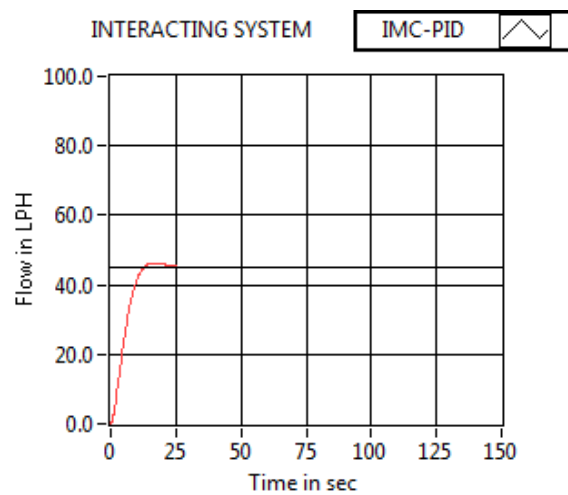

Fig. 7 Response of IMC- PID Control Action for Interacting System to Setpoint 45cm

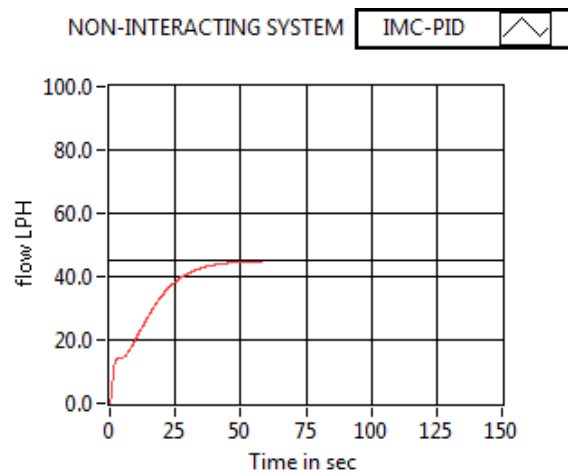

Fig. 8 Response of IMC- PID Control Action for Non-Interacting System to Setpoint 45cm



Table II Performance Analysis of Controller

Control Action	Process Type	Performance Analysis				
		t_d (sec)	t_r (sec)	t_p (sec)	M_p %	ISE
PID	Non-Interacting	10	19	139	20.288	1.5
	Interacting	11	16	31	9.207	1.54
IMC-PID	Non-Interacting	6	13	0	0	0.8
	Interacting	9	14	0	0	1.50
IMC	Non-Interacting	6	13	0	0	1
	Interacting	16	18	51	0	1.32

VI.CONCLUSION

An analysis comes out with a conclusion that the peak time(t_p) and overshoot(M_p) has got reduced drastically in IMC and IMC-PID when compared to conventional PID controller. The rise time(t_r) of the system has improved and the settling time(t_s) and integral square error (ISE) has got reduced in the case of IMC-PID compared to IMC and PID controller shown in table 2 performance analysis.

REFERENCES

- [1] J. G. Ziegler and N. B. Nichols, "Optimum settings for automatic controllers," Trans. ASME, vol. 64, pp. 759–768, 1942.
- [2] J. A. Ramos and P. Lopes dos Santos, "Mathematical Modeling, System Identification, and Controller Design of a Two Tank System" Proceedings of the 46th IEEE Conference on Decision and Control New Orleans, LA, USA, Dec. 12-14, 2007.
- [3] S.Nithya, N.Sivakumaran, T.Balasubramanian, and N.Anantharaman "Model based controller design for a spherical tank Process in real time" IJSSST Vol. 9 No. 4, ISSN 1473-804x Online, 1473-8031, 2008.
- [4] C.E.Garcia and M.Morari, "Internal Model Control Design Procedure for Multivariable Systems", Ind Eng. Chem. Process Des. Dev., 24, pp. 472-484, 1985.
- [5] M. Morari, E. Zafiriou, Robust Process Control, Prentice-Hall, Inc., Englewood Cliffs, N.J, 1989.
- [6] K. J. Åström and T. Hägglund, PID Controllers: Theory, Design, and Tuning. Research Triangle Park, NC: Instrument Soc. Amer., 1995.
- [7] R. Gorez, "A survey of PID auto-tuning methods," J. A, vol. 38, no. 1, pp. 3–10, 1997.
- [8] A. O'Dwyer, Handbook of PI and PID Controller Tuning Rules. London, U.K.: Imperial College Press, 2003.
- [9] Arputha Vijayaselvi, J.; Radhakrishnan, T.K.; Sundaram, S. "Model based IMC controller for process with dead time". Instrum. Sci. Technol 34, pp.463–474, 2006.
- [10] Labview Software.
- [11] B.Wayne Bequette, "Process control – Modeling, Design, and Simulation", PHI, 2006.