



# **Motion Detection Using IoT and Embedded System Concepts**

S.Vishal, G.Prashanth

Project Engineer, Wipro Technologies Guindy, Chennai, Tamil Nadu, India

Project Engineer, CSS Corp Ambathur, Chennai, Tamil Nadu, India

**ABSTRACT:** Nowadays the demands on video surveillance systems are rapidly increasing. Commercial spaces, universities and hospitals, warehouses require of a video capturing system that have ability to alert and record beside live video of the intruder. The current technologies require RFIDs which are costly and hence the security domain in all becomes expensive. Existing solutions have to assist their users for a wide variety of orthogonal designed based on a real time operating system that is raspbian as an exemplar. In this project video surveillance system is presented based on a single board computer represented by Raspberry PI as an embedded solution. The aim is to make a smart surveillance system which can be monitored by owner remotely. As it is connected with the system with IOT, system will send the notifications when an intrusion is detected inside the room. It is required to develop and implement and affordable low cost web-camera based surveillance system for remote security monitoring. Authorized user can access to their monitoring system remotely via internet with the use a mobile phone and monitor the situation on application. This entire work is done on raspberry pi with Raspbian operating system ported on it.

**KEYWORDS:** RFID, IoT, Raspberry PI , PIR sensor , Ethernet Port.

## **I. INTRODUCTION**

People are witnessing the dawn of a new era of Internet of Things (IoT; also known as Internet of Objects). Embedded systems invade the daily life of people as they are used within all kinds of devices such as entertainment, communication and transportation. The existing project (Yi Gu1, Myoungjin Kim1, Yun Cui1, Hanku Lee [2]) the surveillance camera are used to monitor the security in homes and in order to expand the usability, they have proposed the UPnP-based home surveillance camera system (USCS), which employs UPnP technology to search, control, and manage IP based cameras. . In this paper a new system that integrates the UPnP control module into the Open Service Gateway Initiative (OSGi) framework to access UPnP services for a remote network is proposed. This new system showed improved searching, management, discovery, and manipulation of IP-based cameras in a home network compared to a conventional system.

This project describes the use of low cost single – board computer Raspberry Pi with wireless internet. This work is focused on developing a surveillance system that detects stranger and to response speedily by capturing and relaying images to admin office based wireless module and thus activate the alert system both at intruder location and office admin. The adopted system of surveillance is based on a networked single board computer, raspberry pi, motion section and videoing system which presents the idea of monitoring a particular place in a remote area. The system can be administrated by a remote user from any workstation. The usage of RFID increases the overall cost of the project and thus reducing the number of application the project is used for. The new technology is less expensive and longer life of remote battery powered units. The project aims to develop a surveillance embedded system which captures and hosting, real time intruder images and arises of alerting alarms. The proposed system has potential benefits for various security applications such as, but not limited to, securing remote area, estate departments, warehouses and surrounding fence. The proposed solution offers efficient stand alone, flexibility to upgrade and cheap development and installation as well as cost effective surveillance solution. The overall objective of this project is to determine the feasibility of utilizing IOT approach to design a robust Surveillance system, to design and construct a reliable and cost effective surveillance management system based SBC that can be deployed efficiently in remote scattered location and small residential complexes, to investigate the performance of the surveillance system based SBC using Raspberry platform, to construct

and test the prototype so as to determine its accuracy and efficiency and in case of any intrusion, provide immediate alert to the owner by taking snapshots and videos and upload to an external server.

## II. HARDWARE MODULE

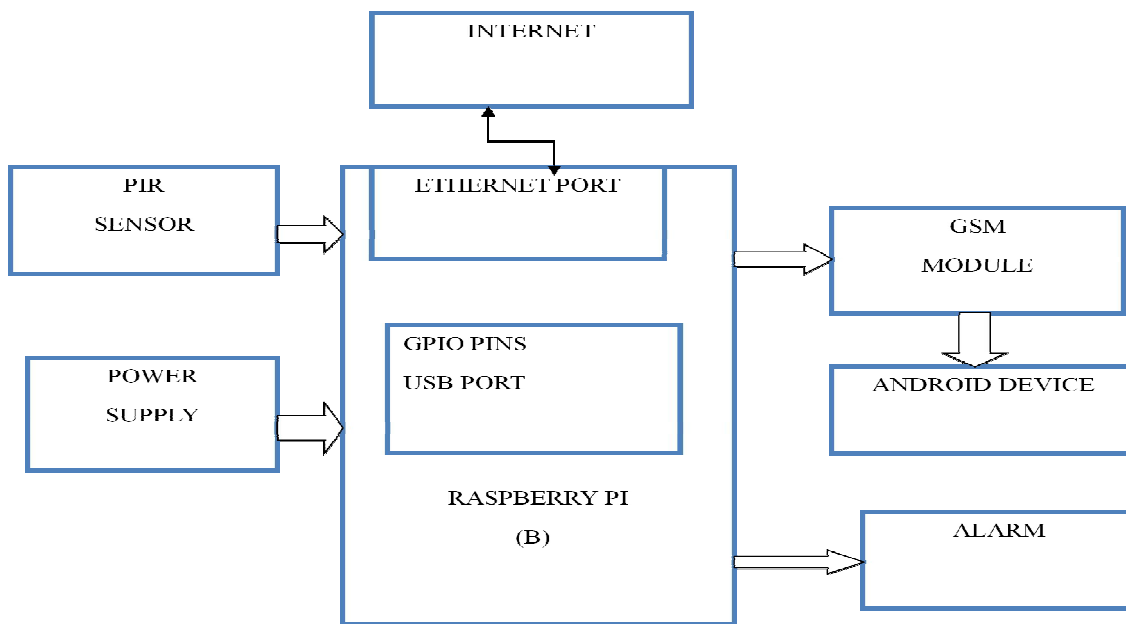

Figure 1: Hardware component of the proposed project.

1. Surveillance System consists of mainly two parts:
  - A. Hard-wired surveillance systems: These systems use wires to connect the cameras, motion detectors, power supply and LAN cable with the pi.
  - B. Remote Access Systems: These systems have the capability to monitor and control a security system from a location away from the surveillance area through android device.
2. USB Camera: USB Camera captures the image and sends it to the USB port of the Raspberry Pi board. The camera model used here is USB Camera model 2.0.
3. Raspberry Pi: Raspberry pi is a small credit-card sized computer capable of performing various functionalities such as in surveillance systems, military applications, etc. The operating system used here is Raspbian OS. Raspbian OS has to be installed so that the image can be transmitted to the smart phone
4. Android device: To view the captured images remotely and also receive the notification message.
5. PIR sensor: It is abbreviated as Passive Infrared Sensor and this sensor is mainly used to detect the motion in surveillance area The input power supply is 3.3V to 5V input voltage. The sensitivity range up to 20 feet (6 meters) 110 degrees \* 60 degrees.

# International Journal of Advanced Research in Electrical, Electronics and Instrumentation Engineering

(An ISO 3297: 2007 Certified Organization)

Vol. 5, Issue 10, October 2016

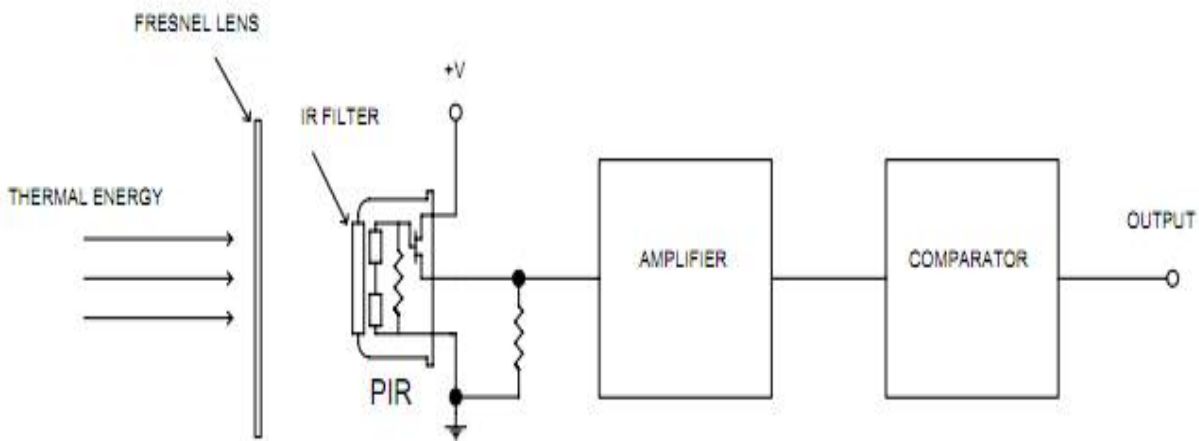

Figure 2: Typical configuration of PIR sensor.

6. Battery Pack: Power Rechargeable lithium ion battery, USB pack of possibly 10000 mAh equipped with charging circuit, and two boost converters which supply 5VDC over 1Amp USB port. The battery pack may be used when the main electric supply is shut down. It can supply the raspberry pi and keep working for more than 48hours
7. GSM Module: A GSM modem is a specialized type of modem which accepts a SIM card, and operates over a subscription to a mobile operator, just like a mobile phone.

### III. SOFTWARE MODULE

The propose system is based Linux operating system as a software platform. It is mainly composed of several function modules; the main function of each module is as follows.

- System initialization and setting module.
- Daytime monitoring.
- Sensor continuous sampling module.
- Image capture module: activated when the PIR sensor interrupts the system. The module will capture the spatial image and pass it to the main board.
- Image processing module: the objective of this module is to identify the captured object in the monitoring scheme.
- Image transmission module: It's used to pass the image to the main admin monitoring system using wireless communication media.

The software tools used are

1. NOOBS: Noobs is designed to make it easy to select and install operating systems for the Raspberry Pi without having to worry about manually imaging your SD card. On first boot NOOBS will format your SD card and allow you to select which OS as you want to install from a list. This OS list is automatically generated from both locally available OS es and those available from our remote repository.
2. PUTTY: Putty is a free and open-source terminal emulator, serial console and network file transfer application. It supports several network protocols, including SCP, SSH, Telnet, rlogin, and raw socket connection. It can also connect to a serial port..
3. PYTHON: Python is a very powerful high-level, object-oriented programming language. It is an interpreted language. Driving the Raspberry Pi's I/O lines requires a bit of programming and Python is the most preferred because Raspbian comes preloaded with Python, the official programming language of the Raspberry Pi and IDLE.
4. RASPBIAN OS: Raspbian is a free operating system based on Debian optimized for the Raspberry Pi hardware. An operating system is the set of basic programs and utilities that make your Raspberry Pi run.

# International Journal of Advanced Research in Electrical, Electronics and Instrumentation Engineering

(An ISO 3297: 2007 Certified Organization)

Vol. 5, Issue 10, October 2016

## IV. FLOWCHART

The project mainly emphasizes the importance of security and privacy in all required places and thus this project produces a satisfactory solution for a long-term standing problem.

Step 1: The system is initialized and configured. The software of this project includes modules such as Videoing module, Motion detection module, alerting module, networking module, Web server module and actuators module. These modules are included just to recognize whether the original user is using the system or an intruder is trying to use.

Step 2: It is then sent to the image and video processing module where the face and attributes of the person using the system is thoroughly checked and compared with the standards that is being set by the user through a wireless networking channel.

Step 3: If the face and the attributes match with the prescribed standards, then the alerting module becomes inactive and the interrupt is driven to zero. If the face and attribute does not match with the standards then the interrupt is driven to one and the control is given to the admin warning system.

Step 4: The image of the intruder is captured and it is recorded.

Step 5: This image is then sent as message to the mobile phone of the user and also as an e-mail to the user given email-id. Then the security activation process is undertaken. The picture of the intruder is taken and is sent to the email which will clearly identify the image of the intruder.

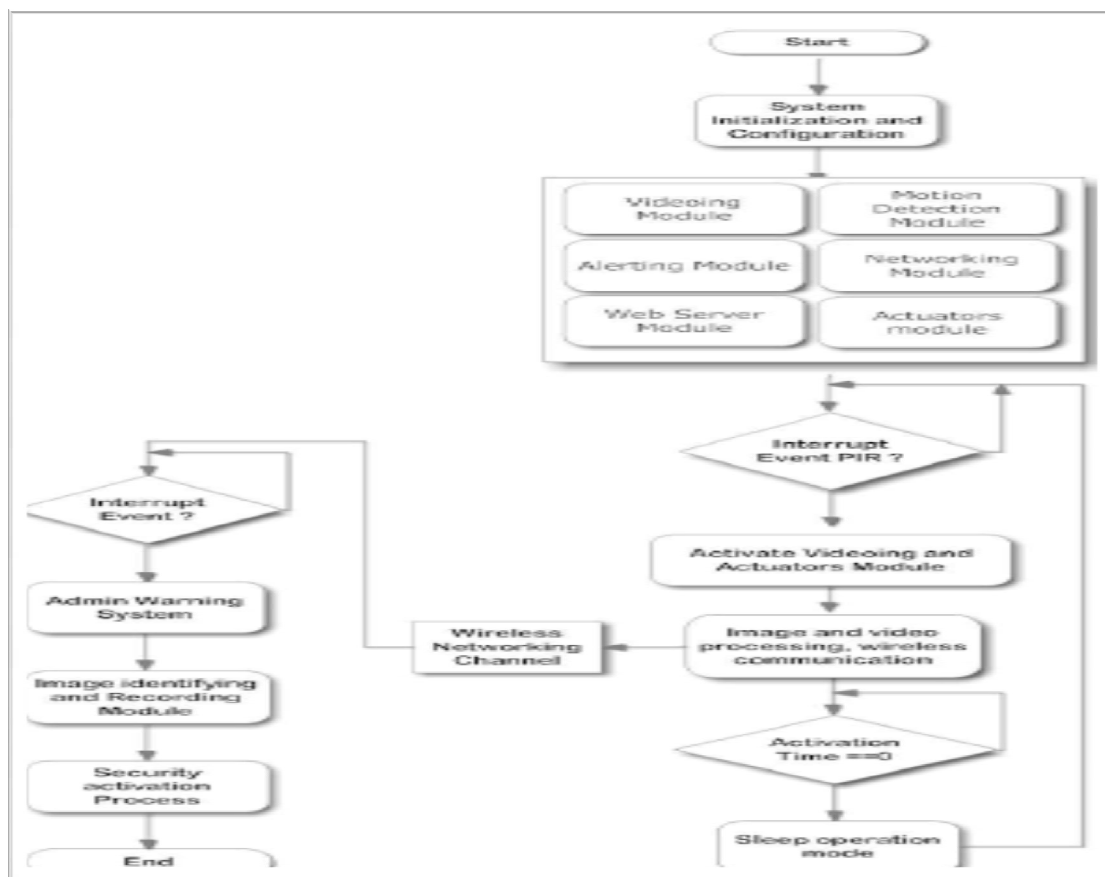

FIGURE 3: Flowchart to the entire system



# International Journal of Advanced Research in Electrical, Electronics and Instrumentation Engineering

(An ISO 3297: 2007 Certified Organization)

Vol. 5, Issue 10, October 2016

## VI. RESULT AND DISCUSSION

If an intruder enters, the face of the intruder is captured with the help of camera and it is sent as an email to the user's email-id. It is also sent as a text message to the user's mobile so that the user can know that someone else is trying to use the system without proper authentication.

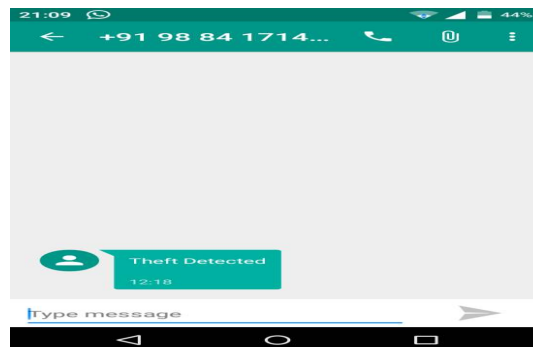

Figure 4: Text message sent to a mobile number of the user.

In the text message, the user is given a knowledge that someone is trying to use the system without his/her knowledge. If the user fails to note the message at the proper time, the picture of the intruder is sent as an email.

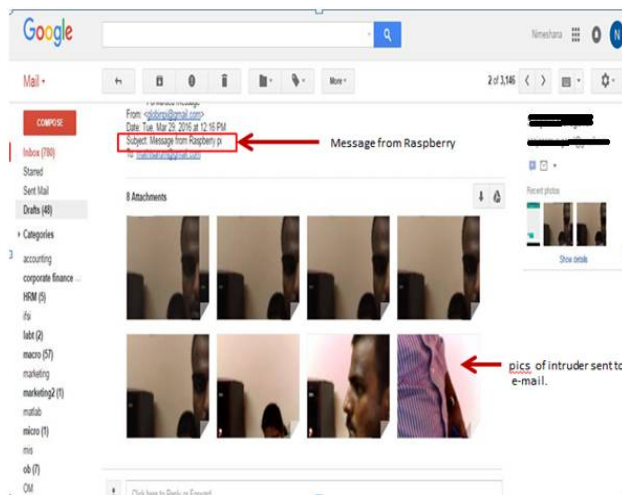

Figure 5: Picture of the intruder sent via email.

## VII. PROPOSED FUTURE WORKS

In future we can use a rechargeable battery for supply so that the system can continue to function even if the main supply is cut off. Even at the case of power shut down, the system tends to work with the rechargeable battery. This system can also be integrated with the door lock so that the user can control the opening and closing of the door in case of emergency situations. If there is any intruder trying to use the system, then doors can be shut and the intruder could be caught.



ISSN (Print) : 2320 – 3765  
ISSN (Online): 2278 – 8875

# International Journal of Advanced Research in Electrical, Electronics and Instrumentation Engineering

(An ISO 3297: 2007 Certified Organization)

Vol. 5, Issue 10, October 2016

## VIII. CONCLUSION

We have designed a smart surveillance system capable of recording/capturing video/image and transmitting to a smart phone and ftp server. It is advantageous as it offers reliability and privacy on both sides. It is authenticated and encrypted on the receiver side also. Hence it offers only the person concerned to view the details. Necessary action can be taken in short span of time in the case of emergency conditions like intrusion. IOT approach offers an alternate means to design a reliable Security system compared to conventional CCTVs. The upfront cost of the systems is potentially lesser compared to conventional systems. Thus, a security monitoring system controlled by Raspberry Pi has been implemented and tested. The power electronics part of the system and the underlying Python code script were optimally designed/coded, realised and tested. The implementation of IOT approach has provided a real time monitoring of the target area. An alert SMS message and an E-mail containing the images of the intruders are received instantaneously within 10 seconds. The Python code has been effectively tested to rectify any possible bugs. It was able to efficiently compare the past frames/sec and present frames per second to detect any motion. The usage of Raspberry Pi has optimised the system and brought down the cost drastically compared to conventional CCTVs. The overall cost of the system would be in the range of less than \$60 (Mass Production). Laboratory test results of the whole system were found to agree well with the planned performance. The proposed Surveillance system has long lifetime and it is maintenance free. According to the test results it provides satisfactory performance under any given environmental conditions. Together with decreasing the costs and increasing efficiency, the Security is getting more pervasive than ever. Connected home security systems are connected via the cloud to a mobile device or the web for remote monitoring, and come with a variety of features such as motion detectors, door and window sensors and video cameras with recording capabilities. The proposed system is simple in design, easy to install and is highly reliable. These systems are highly comprehensive at the same time are affordable also. Therefore this kind of real time Surveillance system has great prospect of in building a secured digital world.

## REFERENCES

1. Wai Zhao, Jayanand Jegatheesan and Son Chee Loon(2015) Exploring “IOT Application Using Raspberry Pi, International Journal of Computer Networks and Applications”, Vol 2, Issue 1, January - February, 2015
2. Yi Gu1, Myoungjin Kim1, Yun Cui1 and Hanku (2014) “An UPnP-Based Surveillance Camera System for Home Security”, International Journal of Distributed Sensor Networks Vol 5, 2014
3. Padmashree A. Shake and Sumedha S. Borde(2015), “Designing Approach of an Intruder Realtime Ubiquitous Embedded Surveillance System”, Journal of Theoretical and Applied Information Technology Vol 79, 2015
4. Jadhav, G. J(2014), “Design and Implementation of Advanced ARM Based Surveillance System using Wireless Communication, International Journal of Advance Research in Computer Science and Management Studies” Vol 2 , 2014
5. Khandavalli Michael Angelo and Karthik(2014), “Arm Based Remote Surveillance and Motion Detection System by Using MJPEG Algorithm”, IEEE Conf April 2014.
6. Priya B. Patel, Viraj M. Choksi, Swapna Jadhav, M.B. Potdar, PhD(2016) “Smart Motion Detection System using Raspberry Pi”, International Journal of Applied Information Systems (IJ AIS), Vol10 – No.5, February 2016.
7. International journal of advanced research in computer and communication engineering Vol 1, Issue 8, October 2012. International journal of emerging technology and advanced engineering (ISSN 2250-2459) Volume 4, Issue 3, March 2014.
8. Telaprolu, M.K, sarma, V.V.ratankanth, E.K.Rao, SN.Banda, vehicular Electronics and safety (ICVES), IEEE International Conference pune (2009).
9. Muthukumar S, Dr.Krishnan .N, Pasupathi.P, Deepa. S, “Analysis of Image Inpainting Techniques with Exemplar, Poisson, Successive Elimination and 8 Pixel Neighborhood Methods”, International Journal of Computer Applications (0975 – 8887), Volume 9, No.11, 2010