



# Sliding Mode Control Based Improved Linear Sinusoidal Tracer Control Algorithm for DSTATCOM

Anu Rachel Alexander<sup>1</sup> H.Brindha<sup>2</sup>

PG Student, Dept of EEE, GKM College of Engineering and Technology, Chennai, India<sup>1</sup>

Assistant Professor, Dept of EEE, GKM College of Engineering and Technology, Chennai, India<sup>2</sup>

**ABSTRACT:** The development in the field of power electronic equipment, the intensive use of static converters, and the great number of domestic electronic-based applications have deteriorated the quality of the power. These nonlinear loads generate current harmonics that can be asymmetric and can cause voltage drops on the supply network impedance resulting in unbalanced conditions. These effects can be worse in the case where the loads change randomly. Conventional solutions like passive filters for reducing the current harmonic pollution are ineffective since they can eliminate only a particular frequency range and another unit required for eliminating next frequency range and so on.

This paper presents a three-phase distribution static compensator (DSTATCOM) using sliding mode control based improved linear sinusoidal tracer (ILST) control algorithm for different functions of DSTATCOM such as reactive power compensation for power factor correction, harmonics elimination, and load balancing under nonlinear loads. This control scheme uses the internal model principle of reference currents for achieving from the source and load current. Thus the effectiveness of the system is very improved. The proposed system is simulated under PI controller and fuzzy controller. This results in the better quality of power at the distribution side. It is important to emphasize that the proposed system gives excellent results compared to the conventional methods. The simulation results using MATLAB/SIMULINK are verified for the proposed DSTATCOM.

**Keywords:** Sliding mode control (SMC) Improved linear sinusoidal tracer (ILST) control algorithm, power factor correction (PFC), power quality, reactive power.

## I. INTRODUCTION

Improved power quality is the primary requirement of any electric distribution system. It has many advantages such as maximum utilization of electrical equipments, enhanced loading capability, zero voltage regulation (ZVR), etc. [1]. Sources of poor power quality can be divided based on consumer loads and subsystem of a distribution system. These consumer loads can be classified as linear, nonlinear, or mixed type of loads [2]. Power electronics-based shunt custom power device, known as a distribution static compensator (DSTATCOM), is used for the compensation of reactive power, unbalance, and harmonics of these loads in a medium-voltage distribution system [3], [4]. An active shunt compensator can be operated as a variable conductance for different order of harmonics corresponding to voltage harmonics distortion such that this technology is also useful for suppression of harmonics resonance in the distribution system [5]. Various configurations and topologies of DSTATCOM are used for reduction of distortions with acceptable level of performance according to the IEEE-519 standard with an optimal use of dc bus of a voltage source converter (VSC) used as DSTATCOM and in cost-effective manner [6]–[10]. DSTATCOM has supportive characteristics as solution for a current-related power-quality problem in many applications.

Various discussions have explained its application in small hydropower generation using instantaneous reactive power theory control algorithm. Singh and Solanki have explained its implementation in the diesel engine-based isolated-power generating system for reactive power compensation and harmonic suppression. Hu *et al.* have described its application in aircraft power system for their supply frequency. In the wind-power generation system, it is applied for voltage and frequency control along with harmonic compensation. Verma *et al.* have described an application of this shunt compensator in the solar PVfarm to regulate the grid voltage. In this application, the VSC can be utilized for voltage regulation during night when the sun is not available.

# International Journal of Advanced Research in Electrical, Electronics and Instrumentation Engineering

(An ISO 3297: 2007 Certified Organization)

Vol. 3, Special Issue 4, May 2014

Effective use of DSTATCOM is directly related to the design of power circuit components such as dc-bus capacitor, interfacing inductors, and VSC, control algorithm used for the estimation of reference source currents with increased speed and less calculation, switching scheme for gating pulses, and stability issues of a designed control algorithm.

In sliding mode control theory-based improved linear sinusoidal tracer control algorithm is implemented on a DSTATCOM for the extraction of load currents fundamental components in three phase consumer loads. It is used for power factor correction (PFC) and ZVR along with load balancing and harmonics elimination. A good detection accuracy, wide range of adjustment of internal parameters, stability performance, and fast dynamic response are the main features of this control algorithm. Internal parameters of this algorithm have clear physical understanding and easy adjustable to optimal value, which show the simplicity of this algorithm. Frequency- and time-domain characteristics of the ILST are not affected due to external environment changes. Detection accuracy and speed of the dynamic response can be tuned after adjusting algorithm internal parameters. For the desired frequency and bandwidth, the ILST control algorithm is able to extract instantaneous value and the amplitude of a sinusoidal by least-squares error, gradient descent method, and rotation transform.

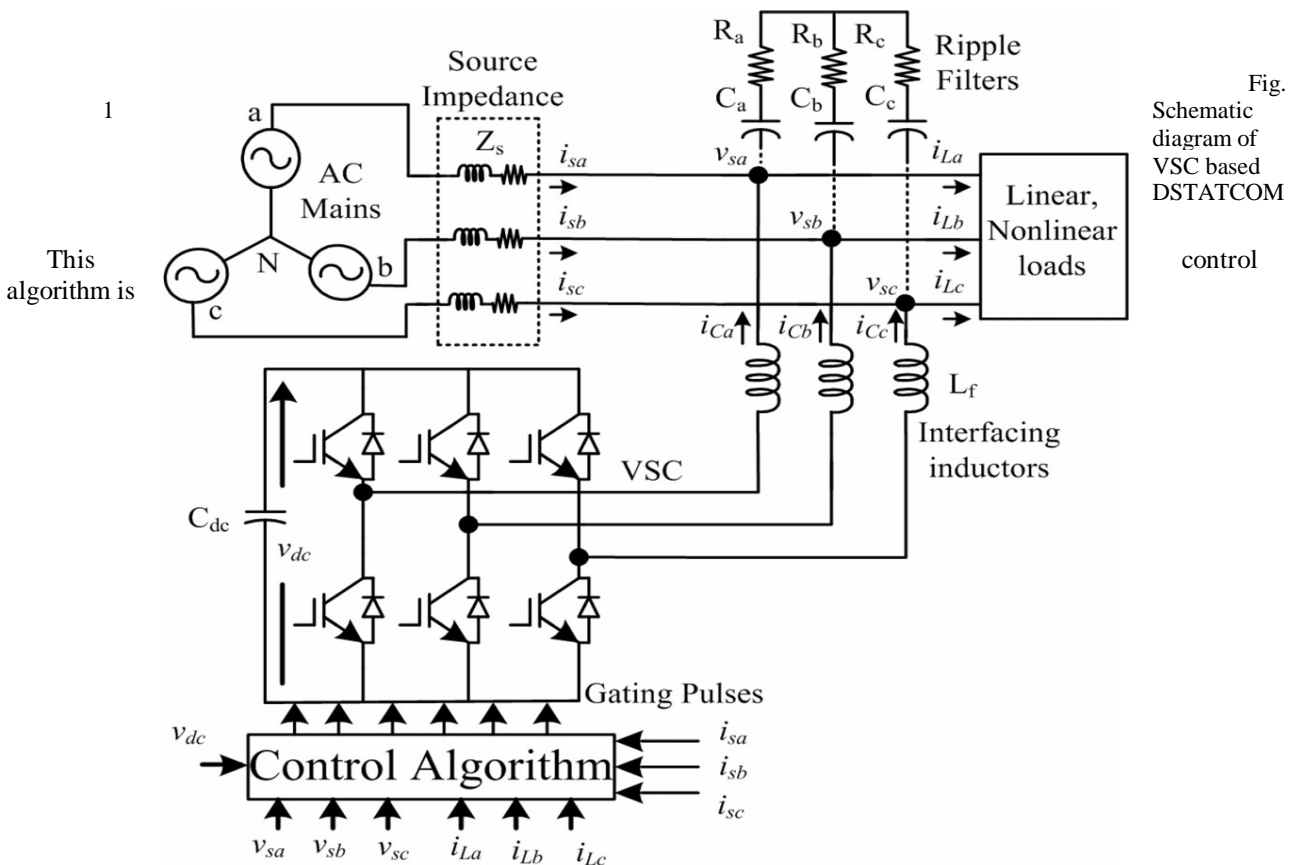

implemented on a DSTATCOM for compensation of linear and nonlinear loads.

## II. SYSTEM CONFIGURATION

A VSC-based DSTATCOM is shown in figure 1. It is connected to a three-phase ac mains feeding three-phase linear/nonlinear loads with grid source impedance  $Z_s$ . For reducing ripple in compensating currents, interfacing inductors  $L_f$  are used at an ac side of the VSC. A three-phase series combination of capacitor ( $C_a$ ,  $C_b$ ,  $C_c$ ) and a resistor ( $R_a$ ,  $R_b$ ,  $R_c$ ) represent the passive ripple filter, which is connected at point of common coupling (PCC) for filtering the high frequency switching noise of the VSC. Generally, the same value of series-connected capacitor and



# International Journal of Advanced Research in Electrical, Electronics and Instrumentation Engineering

(An ISO 3297: 2007 Certified Organization)

Vol. 3, Special Issue 4, May 2014

resistance as a ripple filter is used in all the three phases. The DSTATCOM currents  $i_{CabC}$  are injected as required compensating currents to cancel the reactive power components and harmonics of the load currents so that loading due to reactive power component/harmonics is reduced on the distribution system. The rating of the insulated gate bipolar transistor (IGBT) switches of the VSC is based on the voltage and current rating for the required compensation. The rating of the VSC for the reactive power compensation/harmonics elimination is found to be 35 kVA (approximate 15% higher than the reactive power from rated value).

### III. SLIDING MODE ILST CONTROL ALGORITHM

In control theory, sliding mode control or SMC is a non linear control method that alters the dynamics of a non linear system by application of a discontinuous control signal that forces the system to slide along a cross-section of the systems normal behaviour. The state-feedback control law is not a continuous function of time. Instead, it can switch from one continuous structure to another based on the current position in the state space. Hence, sliding mode control is a variable structure control method. The multiple control structures are designed so that trajectories always move toward an adjacent region with a different control structure, and so the ultimate trajectory will not exist entirely within one control structure. Instead, it will *slide* along the boundaries of the control structures. The motion of the system as it slides along these boundaries is called a *sliding mode* and the geometrical locus consisting of the boundaries is called the *sliding (hyper)surface*. In the context of modern control theory, any variable structure system, like a system under SMC, may be viewed as a special case of a hybrid dynamical system as the system both flows through a continuous state space but also moves through different discrete control modes.

In this paper, one application of sliding mode controllers is the control of electric drives operated by switching power converters. Because of the discontinuous operating mode of those converters, a discontinuous sliding mode controller is a natural implementation choice over continuous controllers that may need to be applied by means of pulse-width modulation or a similar technique of applying a continuous signal to an output that can only take discrete states.

A Passivity-Based Sliding Mode (PBSM) approach is proposed in this paper for designing nonlinear STATCOM controller. The energy-dissipative properties of the proposed model derived in the synchronous d-q rotating frame are fully retained. Furthermore, this model also considers the operation condition under a changeable load model. The proposed controller design is separated into the inner loop and the outer loop controller. In the inner loop, passivity-based control is employed by using energy shaping and damping injection techniques to generate the proper switching function for Voltage Source Converter (VSC)-based STATCOM. The load terminal voltage and the DC-side voltage dynamics are regulated via the outer loop controller cascaded to the inner loop controller. The outer loop control is employed by two sliding mode controllers to determine the appropriate current command. Simulation results are presented to show efficacy of the resulting PBSM controller with regard to voltage regulation and reactive power compensation.

#### A. DESIGN CALCULATIONS

AC supply source: three-phase, 415 V, 50 Hz; load: Nonlinear: three-phase full-bridge uncontrolled rectifier with  $R = 12 \Omega$  and  $L = 100 \text{ mH}$ ; dc-bus capacitance:  $500e-6 \mu\text{F}$ ; reference dc-bus voltage: 2000 V; interfacing inductor  $L_f = 2.25 \text{ mH}$ ; cutoff frequency of a low-pass filter used in dc bus = 10 Hz.

$$V_a = [V_d \sin(\omega t) + V_q \cos(\omega t) + V_o]$$

$$V_b = [V_d \sin(\omega t - 2\pi/3) + V_q \cos(\omega t - 2\pi/3) + V_o]$$

$$V_c = [V_d \sin(\omega t + 2\pi/3) + V_q \cos(\omega t + 2\pi/3) + V_o]$$

POWER FACTOR= ACTIVE POWER



## International Journal of Advanced Research in Electrical, Electronics and Instrumentation Engineering

(An ISO 3297: 2007 Certified Organization)

Vol. 3, Special Issue 4, May 2014

APPARENT POWER

$$\text{ACTIVE POWER} = \sqrt{3} V_L I_L \cos \phi$$

$$\text{REACTIVE POWER} = \sqrt{3} V_L I_L \sin \phi$$

$$\text{APPARENT POWER} = \sqrt{3} V_L I_L$$

$$\text{POWER FACTOR} = \frac{\sqrt{3} V_L I_L \cos \phi}{\sqrt{3} V_L I_L} = \cos \phi = 0.8389 \text{ (FOR PI CONTROLLER)}$$

$$\text{POWER FACTOR} = \frac{\sqrt{3} V_L I_L \cos \phi}{\sqrt{3} V_L I_L} = \cos \phi = 0.8715 \text{ (FOR FUZZY CONTROLLER)}$$

$$V_{DC} = \frac{3\sqrt{3} V_S \cos \phi}{\pi}$$

$\pi$

$$V_{DC} = \frac{3\sqrt{3} V_S}{\pi} = 750V$$

$\pi$

$$\text{THD} = \frac{\sqrt{V_2^2 + V_3^2 + \dots + V_M^N}}{\sqrt{V_1^2}} = 2.95\% \text{ (FOR PI CONTROLLER)}$$

$$\text{THD} = \frac{\sqrt{V_2^2 + V_3^2 + \dots + V_M^N}}{\sqrt{V_1^2}} = 2.95\% \text{ (FOR FUZZY CONTROLLER)}$$

### IV. SIMULATION RESULTS AND DISCUSSION

Matlab with simulink is used for the development of simulation model of a DSTATCOM and its control algorithm. The performance of ILST-based control algorithm in tie domain for the three phase DSTATCOM is simulated for PFC and ZVR operation at linear and non linear loads using developed matlab model. DSTATCOM is a shunt reactive power compensation device and here we are using a six pulse voltage source inverter connected to the distribution side at the point of common coupling. The gate triggering of each mosfet plays an important role. The gate pulse is given by PWM technique.

# International Journal of Advanced Research in Electrical, Electronics and Instrumentation Engineering

(An ISO 3297: 2007 Certified Organization)

Vol. 3, Special Issue 4, May 2014

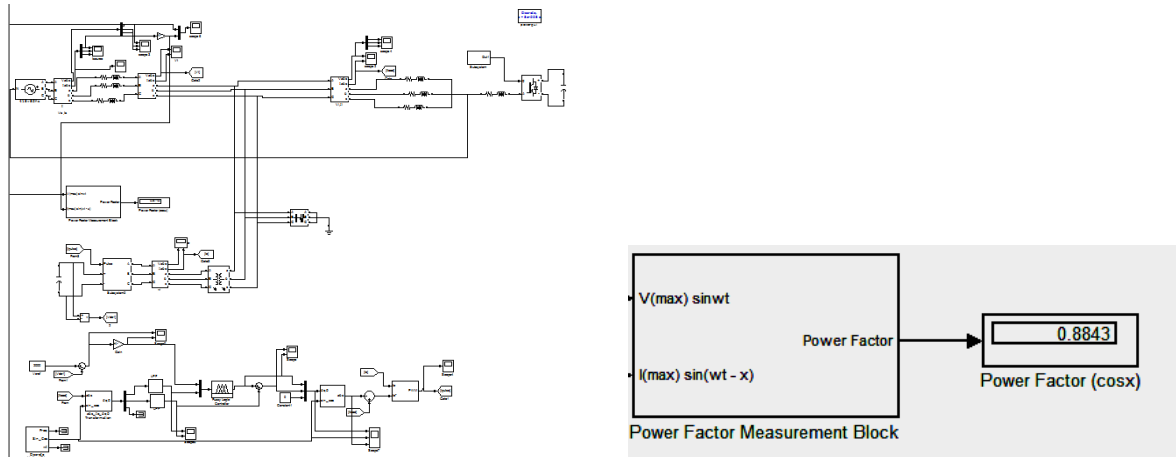

Fig 2 Overview Of Simulation Using fuzzy Controller and PFC readings.

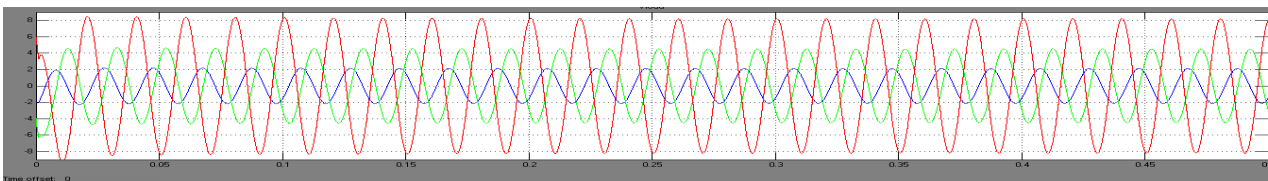

Fig 3 Output for 3phase power

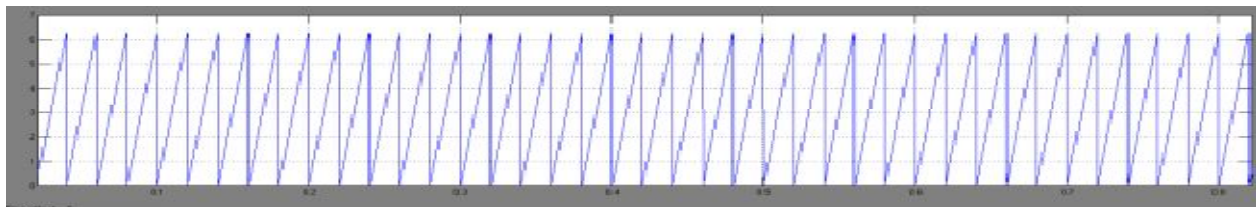

Fig 4 Output of PI controller

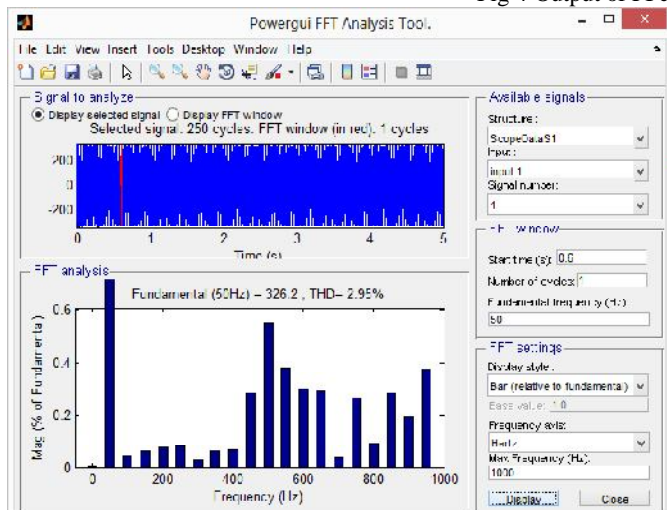

Fig 5 Total harmonic distortion output.

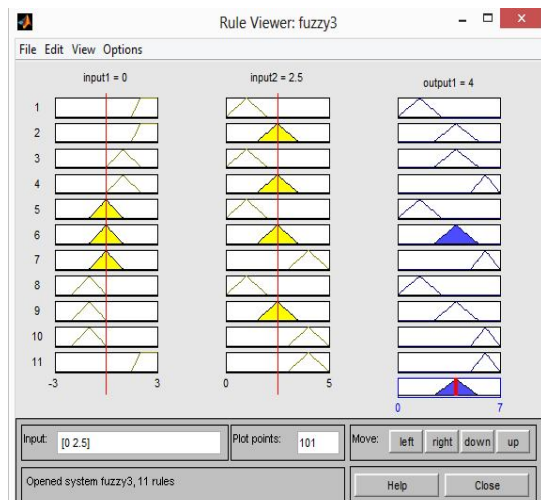

Fig 6 Output of fuzzy logic





# International Journal of Advanced Research in Electrical, Electronics and Instrumentation Engineering

(An ISO 3297: 2007 Certified Organization)

Vol. 3, Special Issue 4, May 2014

TABLE I  
PERFORMANCE OF DSTATCOM

Operating mode	Performance parameters	Linear load	Nonlinear load (3 $\phi$ uncontrol rectifier with R and L load )
PFC mode	PCC voltage (V), %THD	233.6V, 2.43%	237.23V, 2.86%
	Supply current (A), %THD	55.07A, 1.55%	29.21A, 3.19%
	Load current (A), %THD	67.7A, 0.17%	28.53A, 25.98%
ZVR mode	PCC voltage (V), %THD	239.5V, 2.37%	239.56V, 3.14%
	Source current (A), % THD	57.14A, 1.48 %	29.67A, 3.27%
	Load current (A), % THD	69.4A, 0.19%	28.77A, 26.15%
	DC bus voltage (V)	700V	700V

## V. CONCLUSION

A three-phase distribution static compensator (DSTATCOM) using sliding mode control based improved linear sinusoidal tracer control algorithm for different functions of DSTATCOM such as reactive power compensation for power factor correction, harmonics elimination, and load balancing under non linear loads have been implemented. The proposed system have been simulated under PI controller and fuzzy controller. This results in the better quality of power at the distribution side. It is important to emphasize that the proposed system gives excellent results compared to the conventional methods. The simulation results are verified using MATLAB for the proposed system.

## REFERENCES

- [1] T. L. Lee and S. H. hu, "Discrete frequency-tuning active filter to suppress harmonic resonances of closed-loop distribution power systems," *IEEE trans. Power electron.* Vol. 26, no. 1, pp. 137–148, Jan. 2011.
- [2] F. Barrero, S. martínez, F. yeves, and P. M. martínez, "Active power filters for line conditioning: a critical evaluation," *IEEE trans. Power delivery*, vol. 15, no. 1, pp. 319–325, jan. 2000.
- [3] J.C. Wu, h.-l. Jou, y.-t. Feng, w.-p. Hsu, M.-s. Huang, and W.-j. Hou, "Novel circuit topology for three-phase active power filter," *IEEE trans. Power delivery*, vol. 22, no. 1, pp. 444–449, Jan. 2007.
- [4] K. Sano and M. Takasaki, "A transformerless dstatcom based on a multivoltage cascade converter requiring no dc sources," *IEEE trans. Power electron.*, vol. 27, no. 6, pp. 2783–2795, Jun. 2012.
- [5] S. Du, J. Liu, and J. Lin, "Hybrid cascaded h-bridge converter for harmonic current compensation," *IEEE trans. Power electron*, vol. 28, no. 5, pp. 2170–2179, may 2013.
- [6] L. Asiminoaei, C. Lascu, F. Blaabjerg, and I. Boldea, "Performance improvement of shunt active power filter with dual parallel topology," *IEEE trans. Power electron.*, vol. 22, no. 1, pp. 247–259, Jan. 2007.
- [7] S. B. Karanki, N. Gedda, M. K. Mishra, and B. K. Kumar, "A dstatcom topology with reduced dc link voltage rating for load compensation with non-stiff source," *IEEE trans. Power electron.*, vol. 27, no. 3, pp. 1201–1211, mar. 2012.
- [8] B. Singh and J. Solanki, "Load compensation for diesel generator-based isolated generation system employing dstatcom," *IEEE trans. Ind. Appl.*, vol. 47, no. 1, pp. 238–244, Jan./Feb. 2011.
- [9] H. Hu, W. Shi, Y. Lu, and Y. Xing, "Design considerations for dsp controlled 400 hz shunt active power filter in an aircraft power system," *IEEE trans. Ind. Electron.*, vol. 59, no. 9, pp. 3624–3634, Sep. 2012.
- [10] S. Sharma and B. Singh, "Performance of voltage and frequency controller in isolated wind power generation for a three-phase four-wire system," *IEEE trans. Power electron.*, vol. 26, no. 12, pp. 3443–3452, Dec. 2011.

## BIOGRAPHY



**Anu Rachel Alexander** was born in Trivandrum, India. She received the B.Eng. degree in electrical and electronics engineering from the Anna University, Chennai in 2012 and currently a student doing M.E.in Power System Engineering in GKM College of Engineering And Technology affiliated to Anna University .Her main research interests are power quality, FACTS devices and Power Factor Correction.

**H.Brindha** currently working as assistant professor in G.K.M. College of Engineering and Technology.