



# International Journal of Innovative Research in Computer and Communication Engineering

(An ISO 3297: 2007 Certified Organization)

Vol. 3, Issue 1, January 2015

## Smart Phone Controlled Robot Using ATMEGA328 Microcontroller

Aniket R. Yeole<sup>1</sup>, Sapana M. Bramhankar<sup>2</sup>, Monali D. Wani<sup>3</sup>, Mukesh P. Mahajan<sup>4</sup>

UG Student, Dept. of E&Tc, Sandip Institute of Technology and Research Centre, Nashik, Maharashtra, India<sup>1,2,3</sup>

Assistant Professor, Dept. of E&Tc, Sandip Institute of Technology and Research Centre, Nashik, Maharashtra, India<sup>4</sup>

**ABSTRACT:** Nowadays android smart phones are the most popular gadget. There are multiple applications on the internet that exploit inbuilt hardware in these mobile phones, such as Bluetooth, Wi-Fi and ZigBee technology to control other devices. With the development of modern technology and Android Smartphone, Bluetooth technology aims to exchange data wirelessly at a short distance using radio wave transmission comprising features to create ease, perception and controllability. In this paper we have designed a robot that can be controlled using an application running on an android phone. It sends control command via Bluetooth which has certain features like controlling the speed of the motor, sensing and sharing the information with phone about the direction and distance of the robot from the nearest obstacle.

**KEYWORDS:** Android; ATMEGA328; Bluetooth

### I. INTRODUCTION

Robots have been with us for less than 50 years but the idea of inanimate creations represents a sincere bid whose success is much older. But real robots did not come into existence until 1950s and 60s. With the growing invention of transistors and integrated circuits, computer industry added brains to the brawn of already existing machines. In 1959, researchers illustrated the possibility of robotic manufacturing when they unveiled a computer-controlled milling machine. Bluetooth technology was created by telecom vendor Ericsson in 1994. A Bluetooth device is able to communicate with up to seven Bluetooth modules at same time through one link whose normal working area is within eight meters.

The basic function of Bluetooth serial module is replacing the serial port line by connecting one to Bluetooth master device and the other connecting to slave device. Today, robots are enjoying resurgence. As computer processors are getting faster and inexpensive, robots can afford to get smarter. While, researchers are working on ways to help robots move and “think” more efficiently. Since most robots in use today are designed for specific tasks, our goal is to someday make universal robots that are flexible enough to do just about anything a human does and more.

Android is a software stack for mobile devices that includes an operating system and key applications. Android applications provide access to a wide range of useful libraries and tools that can be used to build rich applications. Android also includes a full set of tools that provides developers with high productivity and deep insight into their applications. Bluetooth is a technology with an open standard specification for a radio frequency (RF)-based short-range connectivity technology that changes the face of computing and wireless communication. The data received by the Blue-tooth module from Android smart phone is fed as input to the controller. Thereby, the controller acts accordingly on the DC motors to move in the entire robot in all the four directions using the Android phone.

### II. RELATED WORK

Existing system are present which uses Bluetooth module HC-06 and 89c2051 micro-controller with an android Smartphone device to control robot/robo. Bluetooth module receives data from smart phone that is fed as input to the controller and it acts accordingly on the DC motor of the robot. The robot can be made to move in all the four directions using the android phone. To achieve this task the controller is loaded with program written using Embedded C [1].

# International Journal of Innovative Research in Computer and Communication Engineering

(An ISO 3297: 2007 Certified Organization)

Vol. 3, Issue 1, January 2015

In [2], android phone controlled robot using Bluetooth analyses the motion technology to capture gestures through an android smart phone with an inbuilt accelerometer and Bluetooth module to control the kinetics of a robot. The paper [3] approached a robotic movement control through the smart phones. Hence a dedicated application is created to control an embedded robotic hardware. The application controls the movement of the robot. The embedded hardware is developed on 8051 microcontroller and to be controlled by a Smartphone on the basis of Android platform. 8051 controller is to receive the AT commands from the Smartphone and takes the data and controls the motors of the robot by the motor driver L293D. In industrial robotic environments there are many different robots performing a variety of tasks. Each robot is controlled by its own teach pendant or via a networked socket application. However, to monitor the status or make minor changes to the programming of the robot, the user must obtain access to the pendant or terminal. In an effort to eliminate this need, this paper introduces an android platform that communicates with robots over a Bluetooth connection. [4] In paper [5] the smart phone supports IFLYTEK voice input and handwritten input, so it is agile, convenient, practical to be used and can ensure the reliability of the whole system, on the other hand, by using Wi-Fi wireless network, the communication between smart phone and robot can be realized, which makes it simple and convenient to control robot to sing and dance in accordance with the commands.

The existing robots are whole operated with the help of remote control. This operation is sometimes tedious, less efficient and has no guarantee for its security. The existing system consists of trade-off between processing speed, insecure communication and cost. With growing trends, controllers are developing tremendously. Hence we can make use of advanced controller in controlling the operation of robot. The proposed project can be built further to work as a HUMANOID. It can have many uses in practical fields, from teenager's robots to robots working in industries. This project can be helpful in wars as a part of spying. It can be further improved to have more decision taking capabilities by employing varied types of sensors and thus could be used in big industries for different applications.

### III. BLOCK DIAGRAM

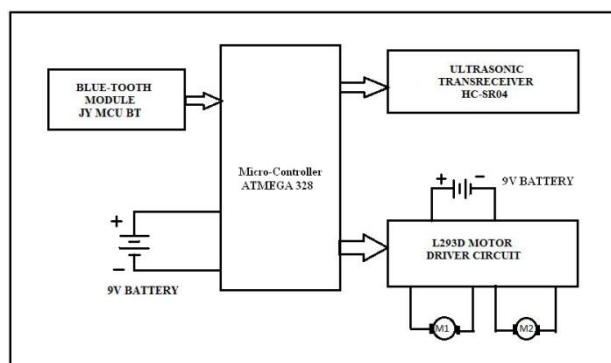

Fig.1. Block diagram of proposed system

It consists of following blocks

- Blue-tooth module-JY MCU BT HC-06
- Micro-Controller -ATMEGA 328
- DC motors
- Ultrasonic transceiver module HC-SR04
- Motor Driver H-Bridge
- 9v Dc battery`

The robot in the project is made to move in all the four directions using the Android phone. The circuit is built around ATMEGA 328 controller board, ultrasonic transceiver module HC-SR04, Blue-tooth module JY MCU BT, motor driver L293D (IC1), DC motors M1 and M2, and a few common components. The circuit uses two 9V batteries. First battery is used to power the ATMEGA 328 controller board and the other is used to power the motors. The regulated



# International Journal of Innovative Research in Computer and Communication Engineering

(An ISO 3297: 2007 Certified Organization)

Vol. 3, Issue 1, January 2015

5V supply for the rest of the circuit is provided by the ATMEGA 328 controller board itself. LED on the board indicates presence of power supply. Motor Driver H-Bridge is used to drive two motors which work on 9v DC batteries. DC motors are interfaced to the Micro controller. The data received by the Blue-tooth module from Android smart phone is fed as input to the controller. The proposed module of Smartphone controlled robot is shown below.

## IV. IMPLEMENTATION

The circuit is built around an ATmega328 controller, ultrasonic transceiver module HC-SR04, Bluetooth module JY MCU BT, motor driver L293D (IC1), DC motors M1 and M2, and a few common components. The circuit uses two 9V batteries—one to power the ATmega328 controller and the other to power the motors. Regulated 5V supply for the rest of the circuit is provided by the ATmega328 controller itself. LED on the board indicates presence of power supply.

### A. Bluetooth module

The module provides a method to connect wirelessly with a PC or Bluetooth phone to transmit/receive embedded data such as GPS data, ADC voltage reading and other parameters. Bluetooth module JY MCU BT used in the project can be connected to any device, via built in UART interface to communicate with other Bluetooth-enabled devices such as mobile phones, handheld computers and laptops. The module runs on a 3.6V to 6V supply.

It consists of following specifications

- Supply voltage can be between 3.6 to 6V DC. I/Os are 5V tolerant.
- Bluetooth V2.0+EDR (Enhanced Data Rate) 3Mbps
- Bluetooth SPP (Serial Port Protocol)
- Easy to connect this module with any standard Bluetooth device, just search and key "1234" passcode.
- Baud rate: 38400 bps.
- Module requires no setup.
- Dimensions: 1.73 in x 0.63 in x 0.28 in (4.4 cm x 1.6 cm x 0.7 cm)

### B. Ultrasonic transceiver module

Ultrasonic transceiver module HC-SR04 uses sonar like bats and dolphins, to determine distance to an object. It offers non-contact range detection of 2cm to 400cm with high accuracy and stable readings in an easy-to-use package. It comes complete with an ultrasonic transmitter and a receiver module.

It consists of following specifications

- Working Voltage DC 5 V
- Working Current 15mA
- Working Frequency 40Hz
- Max Range 4m
- Min Range 2cm
- Measuring Angle 15 degree
- Trigger Input Signal 10uS
- TTL pulse Echo Output Signal
- Input TTL lever signal and the range in proportion
- Dimension 45\*20\*15mm

### C. ATmega328

ATmega328 micro-controller is intended for artists, designers, hobbyists and anyone interested in creating interactive objects or environments.

It consists of following specifications



# International Journal of Innovative Research in Computer and Communication Engineering

(An ISO 3297: 2007 Certified Organization)

Vol. 3, Issue 1, January 2015

- 28-pin AVR Microcontroller
- Flash Program Memory: 32 Kbytes
- EEPROM Data Memory: 1 Kbytes
- SRAM Data Memory: 2 Kbytes
- I/O Pins: 23
- Timers: Two 8-bit / One 16-bit
- A/D Converter: 10-bit Six Channel
- PWM: Six Channels
- RTC: Yes with Separate Oscillator
- MSSP: SPI and I<sup>2</sup>C Master and Slave Support
- USART: Yes

## D. L293d

L293D is a dual H-bridge motor driver integrated circuit (IC). Motor drivers act as current amplifiers since they take a low-current control signal and provide a higher-current signal to run four solenoids, two DC motors or one bi-polar or unipolar stepper with up to 600 mA per channel using the L293D. These are known as the drivers in the Ada fruit Motor shield.

The L293 and L293D are quadruple high-current half-H drivers. In L293 is designed to provide bidirectional drive currents up to 1 A at voltage range from 4.5 V to 36 V. The L293D is designed to provide bidirectional drive currents of up to 600-mA at voltage range from 4.5 V to 36 V. Both the devices are designed to drive inductive loads such as relays, dc and bipolar stepping motor as well as other high-current/high-voltage loads in positive-supply applications.

It consists of following specifications

- 1.2a peak output current (non-repetitive) per channel
- Enable facility
- Over temperature protection
- Logical "0" input voltage up to 1.5 v (high noise immunity)
- Internal clamp diodes
- Wide Supply-Voltage Range: 4.5 V to 36 V
- Separate Input-Logic Supply
- Internal ESD Protection
- Thermal Shutdown
- High-Noise-Immunity Inputs
- Output Current 1 A Per Channel (600 mA for L293D)
- Peak Output Current 2 A per Channel (1.2 A for L293D) Output Clamp Diodes for Inductive Transient Suppression (L293D)

The android application consists of values that operate the robot accordingly. In this application, if '2' is pressed the robot moves "forward"; if '4' is pressed, the robot takes "left turn"; if '6' is pressed the robot takes "right turn"; if '8' is pressed the robot moves "Backward" and if '5' is pressed the robot stops moving. Furthermore if distance between the robot and obstacle is less than 8 cm, the robot stops its movement. The proposed module of Smartphone controlled robot is shown below.

# International Journal of Innovative Research in Computer and Communication Engineering

(An ISO 3297: 2007 Certified Organization)

Vol. 3, Issue 1, January 2015

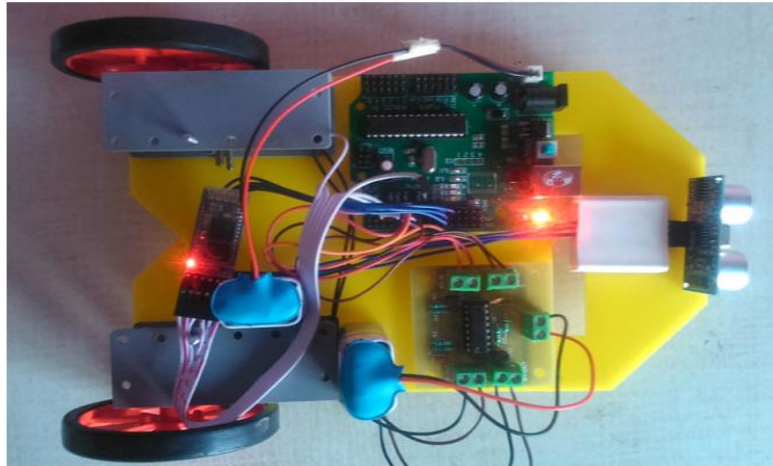

Fig.2 Smartphone controlled robot

## V. APPLICATION & ADVANTAGE

1. The robot is small in size so can be used for spying.
2. This robot can be used in the borders for disposing hidden land mines.
3. The robot can be used for surveillance or reconnaissance.

## VI. FUTURE SCOPE

- It can be built further to work as a HUMANOID.
- It can have many uses in practical fields from teenager's robots to robots working in industries.
- It is helpful in wars as a part of spying.
- The proposed robot can be further improved in terms of decision taking capabilities by employing varied types of sensors and thus could be used in big industries for different applications.

## VII. CONCLUSION

Although this research is still in an early stage of development, it has already proven to succeed in several of its goals. The operating system of smart phone is android which can develop effective remote control program. At the same time, this program uses blue-tooth connection to communicate with robot. It has proven to allow for meaningful two-way communication between the Android phone and the robot which would allow a non-expert to interact with and adjust the functionality of a system which uses ATmega328 controller, a single board micro-controller intended to make the application of interactive objects or environments more accessible.

## REFERENCES

1. Ritikapahuja, Narendra kumar, "Android phone controlled bluetooth robot using 8051 microcontroller", IJSER, Vol. 2, Issue-7, pp 14-17, July 2014
2. Arpit Sharma, Reeteshverma, SaurabhGupta, Sukhdeepkaurbhatia, " Android phone controlled robot using Bluetooth", IJEEE, Vol.7, pp-443-448, Nov- 2014
3. M. Selvam, "Smart phone based robotic control for surveillance application", IJRET, Vol.3, Issue-3, pp-229-232, Mar- 2014.
4. Sebastian van Delden and Andrew Whigham, "A Bluetooth-based Architecture for Android Communication with an Articulated Robot", IEEE, 978-1-4673-1382, pp-104-108, Jul 2012
5. Xiao Lu, Wenjun Liu, Haixia Wang, Qia Sun, "Robot Control Design Based On Smartphone", IEEE, 978-1-4673-1382, pp-2820-2823, Jun 2013